

# **AR-10**

## **10-METER RINGO ANTENNA**



## AR-10 ASSEMBLY

All steps for assembling the ring and tuning assembly to the base section (AA) are shown in figure 1. Mount one ring section (190) to the bottom side of the lower bracket on the base section. Mount the remaining ring section (190) to the top side of the upper bracket on the base section. Connect the two ring sections, forming a circle around the base section.

Assemble the tuning rod clamp (93) with the appropriate hardware. Hold the assembled tuning rod clamp against the bottom side of the lower ring section. Slide the tuning rod (70) through the holes in the tuning rod clamp (93) on the top side of the ring section. See figure 2 for the proper location of the tuning rod. Attach the flattened end of the tuning rod (70) to the bolt extending from the inner coaxial fitting (the one without the black insulator).

Attach the coaxial tuning stub (FF) to the outer coaxial fitting (the fitting below the black insulator), and weatherproof as follows. Coat the threads of the coaxial fitting with silicone grease (116), fig. 4. DO NOT COAT THE CENTER CONNECTOR PIN OR SOCKET. Make sure you only use half of the package as there is one more connection to be weatherproofed. Screw the PL-259 onto the fitting and coat the outside of the connection, making sure to get the back end of the PL-259. Slide the boot over the connector as far as possible.

The radiating section should be layed out in the proper order according to figure 3. All of the tubing should be positioned so that the slotted end is toward the next smallest piece of tubing. Starting at the base insert each section 4" (10.2 cm) into the next larger piece of tubing and secure by tightening the proper size hose clamp. Place the hose clamp close to the end over the slotted portion of each piece of tubing. Adjust tubing section EE according to chart A. Press the 1/2" (1.3 cm) black plastic cap (53) onto tubing section EE. Place the mounting lock nut (249) in the indentation of the base section (AA), so that the four points on the locknut point toward the mast. Thread the mounting screw (81) through the hole in the base section and the mounting locknut. Slide the mast into the base section, tighten the screw and nut securely against the mast as illustrated in figure 1.

## TUNING

The unique AR-10 design features allow the antenna to be tuned for maximum performance at your location. Follow the procedure outlined below after the antenna is mounted on a mast. Do not attempt to tune it while it is on the ground or near any metal objects.

Use a good quality 50 Ohm coaxial feedline with a PL-259 connector. We have supplied you with a weather proof vinyl connector boot (115) for your feedline. To use the connector boot, insert the antenna end of your coaxial feedline through the small end of the connector boot (115). Now attach the PL-259 connector. Coat the threads of the remaining coaxial fitting with silicone. DO NOT COAT THE ENTIRE CONNECTOR PIN OR SOCKET. Screw the PL-259, of your coaxial feedline, onto the coaxial fitting. Apply the remaining silicone to the outside and backside of the PL-259. Slide the connector boot over the connector as far as possible.

To tune the antenna insert a good quality standing wave bridge in the 50 Ohm cable between the signal source and the antenna. CAUTION: DO NOT TOUCH THE ANTENNA WHILE TRANSMITTING, HIGH VOLTAGES EXIST. Adjust the bridge for maximum forward power. Check the standing wave ratio with the bridge in the reverse position. If the VSWR is high, loosen the tuning rod clamp (93) and adjust the tuning rod slightly in either direction. Move away from the antenna and check the reading. If the VSWR has increased, move the tuning rod back to its original position and adjust it in the opposite direction. If the VSWR dropped, repeat the adjustment procedure until there is little or no reflected power indicated on the bridge. Tighten the tuning rod clamp securely.

When the antenna is completely assembled and tuned, run the feedline along the mast and tape it to hold it in place. The tuning stub (FF) should also be taped to the mast.

### RING ASSEMBLY

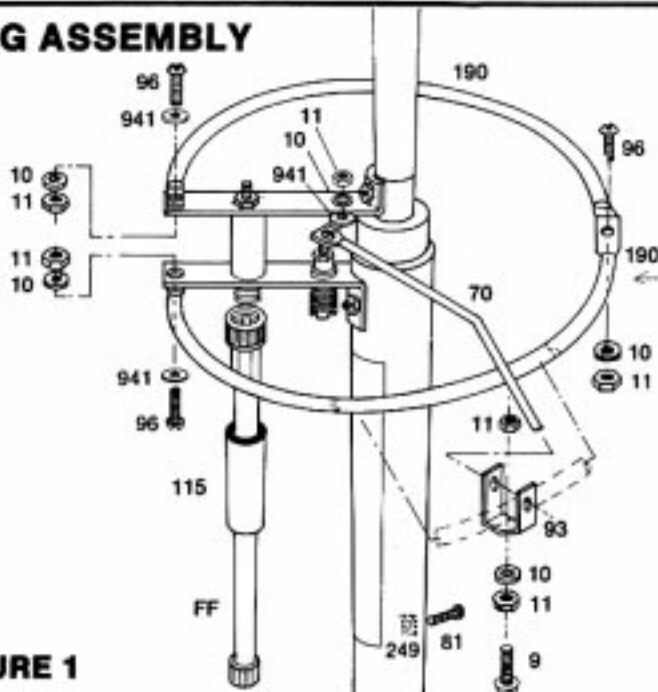

FIGURE 1

### TUNING ROD TAP POINT

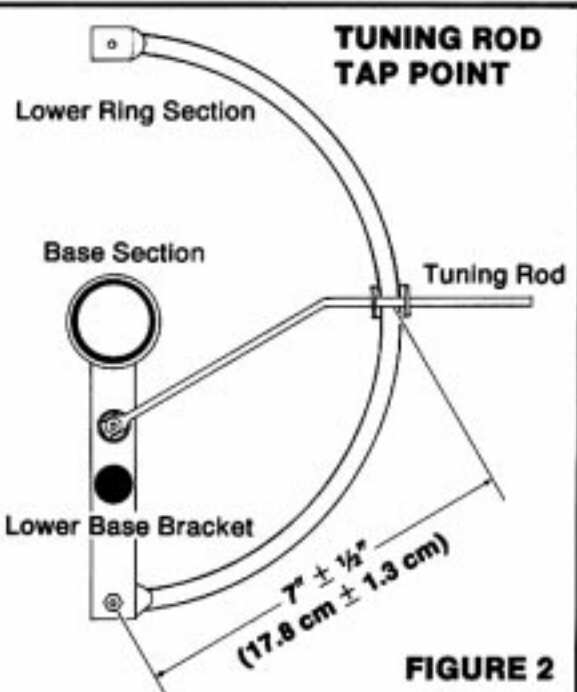
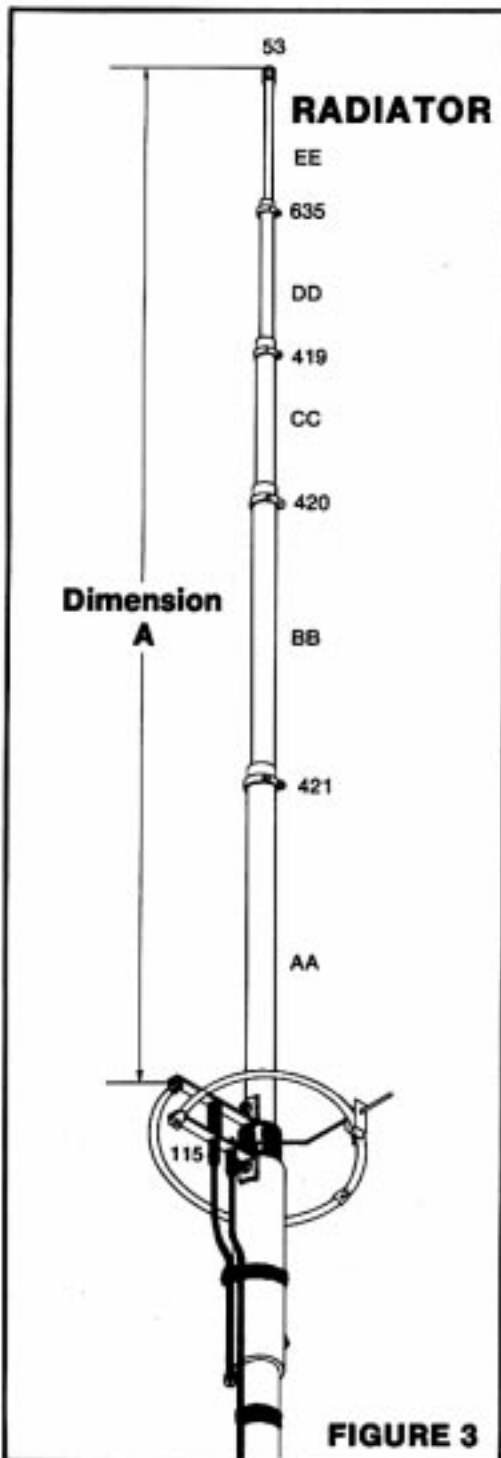

FIGURE 2



**A OVERALL LENGTH CHART**

	<b>DIMENSION A</b> Center Frequency	Length
<b>LOW</b>	28.4 MHz	200"
	28.000-28.800 (max 1.5:1)	(508.0 cm)
<b>MID</b>	28.8 MHz	192"
	28.400 to 29.200 (max 1.5:1)	(487.7 cm)
	28.000 to 29.700 (max 2:1)	
<b>HIGH</b>	29.3 MHz	182"
	28.900 to 29.700 (max 1.5:1)	(462.3 cm)

<b>RING ASSEMBLY PARTS</b>					
P/N	KEY	DETAIL	DESC.	SIZE	QTY.
010009	9		MACHINE SCREW	#8-32 x 3/4" (1.6 cm)	1
010010	10		LOCK WASHER	#8	5
010011	11		HEX NUT	#8-32	6
010096	96		ROUND HEAD SCREW	#8-32 x 3/4" (1.0 cm)	3
010081	81		ROUND HEAD SCREW	1/4"-20 x 3/4" (0.6-20 x 1.9 cm)	1
020249	249		LOCK NUT	1/4"-20 (0.6-20 cm)	1
360941	941		WASHER	1/4" (0.6 cm)	3
050115	115		VINYL BOOT		1
240116	116		SILICONE PACKET		1
200093	93		TUNING ROD CLAMP		1
190190	190		RING SECTION		2
082070	70		TUNING ROD		1
	FF		COAXIAL TUNING STUB.	16 3/4"	1

<b>RADIATOR ASSEMBLY PARTS</b>					
P/N	KEY	DETAIL	DESC.	SIZE	QTY.
030419	419		HOSE CLAMP	3/4" (1.9 cm)	1
030420	420		HOSE CLAMP	3/4" (2.2 cm)	1
030421	421		HOSE CLAMP	1" (2.5 cm)	1
031635	635		TELESCOPE CLAMP	3/4" (1.8 cm)	1
050053	53		BLACK PLASTIC CAP	3/4" (1.3 cm)	1
	AA		BASE ASSEMBLY		1
	BB		ALUMINUM TUBING	3/4" x 48" (2.2 x 121.9 cm)	1
	CC		ALUMINUM TUBING	3/4" x 48" (1.9 x 121.9 cm)	1
	DD		ALUMINUM TUBING	3/4" x 48" (1.6 x 121.9 cm)	1
	EE		ALUMINUM TUBING	3/4" x 48" (1.3 x 121.9 cm)	1
290326	326		WARNING LABEL		1

**FIGURE 4**

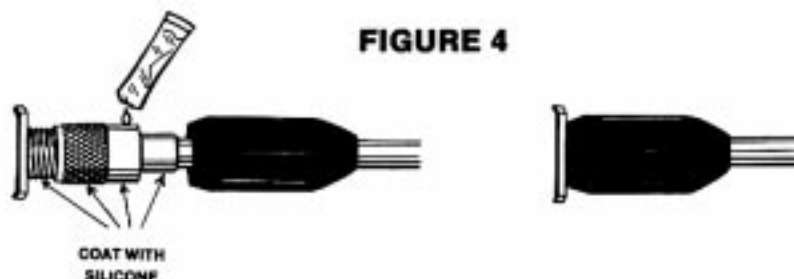

**SPECIFICATIONS**

Gain (Ref. Quarterwave)	3 dB
Nominal Impedance	50 Ohms
VSWR	1.5-1 max over 800 KHz BW 2:1 max Band Edge
Power Handling	1000 Watts
Lightning Protection	DC Ground
Wind Surface Area	1.68 ft <sup>2</sup> (.26 m <sup>2</sup> )
Wind Survival	90 mph (145 kph)
Weight	4 lbs (1.8 kg)
Maximum Height	17' 5" (5.31m)
Termination	PL259 UHF

**LIMITED WARRANTY**

CUSHCRAFT CORPORATION, P.O. BOX 4680, MANCHESTER, NEW HAMPSHIRE 03108, WARRANTS TO THE ORIGINAL CONSUMER PURCHASER FOR ONE YEAR FROM DATE OF PURCHASE THAT EACH CUSHCRAFT ANTENNA IS FREE OF DEFECTS IN MATERIAL OR WORKMANSHIP. IF, IN THE JUDGEMENT OF CUSHCRAFT, ANY SUCH ANTENNA IS DEFECTIVE, THEN CUSHCRAFT CORPORATION WILL, AT ITS OPTION, REPAIR OR REPLACE THE ANTENNA AT ITS EXPENSE WITHIN THIRTY DAYS OF THE DATE THE ANTENNA IS RETURNED (AT PURCHASER'S EXPENSE) TO CUSHCRAFT OR ONE OF ITS AUTHORIZED REPRESENTATIVES. THIS WARRANTY IS IN LIEU OF ALL OTHER EXPRESSED WARRANTIES. ANY IMPLIED WARRANTY IS LIMITED IN DURATION TO ONE YEAR. CUSHCRAFT CORPORATION SHALL NOT BE LIABLE FOR ANY INCIDENTAL OR CONSEQUENTIAL DAMAGES WHICH MAY RESULT FROM A DEFECT. SOME STATES DO NOT ALLOW LIMITATIONS ON HOW LONG AN IMPLIED WARRANTY LASTS OR EXCLUSIONS OR LIMITATIONS OF INCIDENTAL OR CONSEQUENTIAL DAMAGES. SO THE ABOVE LIMITATION AND EXCLUSION MAY NOT APPLY TO YOU. THIS WARRANTY GIVES YOU SPECIFIC LEGAL RIGHTS, AND YOU MAY ALSO HAVE OTHER RIGHTS WHICH VARY FROM STATE TO STATE. THIS WARRANTY DOES NOT EXTEND TO ANY PRODUCTS WHICH HAVE BEEN SUBJECT TO MISUSE, NEGLIGENCE, ACCIDENT OR IMPROPER INSTALLATION. ANY REPAIRS OR ALTERATIONS OUTSIDE OF THE CUSHCRAFT FACTORY WILL NULLIFY THIS WARRANTY.



**THE ANTENNA COMPANY**

48 PERIMETER ROAD, MANCHESTER, NH 03108 USA  
603-627-7877 • TELEX 4949472 • FAX 603-627-1764

SPECIFICATIONS SUBJECT TO CHANGE WITHOUT NOTICE.