

Assembly and Operation of the

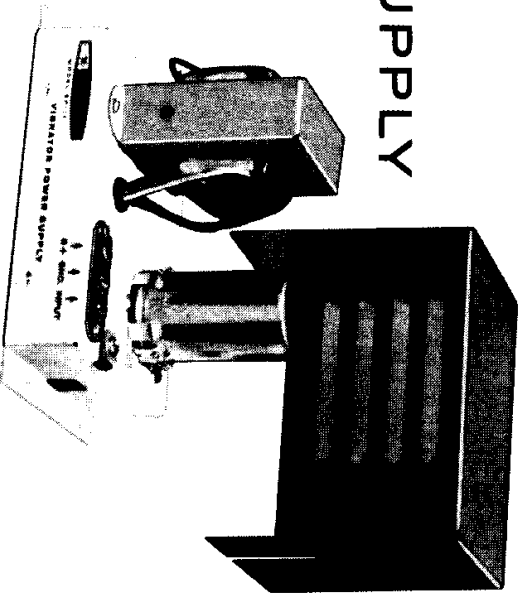

VIBRATOR POWER SUPPLY

MODEL GP-11



All prices are subject to change without notice. The Heath Company reserves the right to discontinue instruments and to change specifications at any time without incurring any obligation to incorporate new features in instruments previously sold.

10/12/62

Copyright 1961
Heath Company

TABLE OF CONTENTS

Specifications.	2
Introduction.	2
Circuit Description.	3
Schematic.	3
Construction Notes.	4
Parts List.	5
Proper Soldering Techniques.	6
Step-By-Step Procedure.	8
Step-By-Step Assembly.	8
Initial Test.	14
Installation.	15
In Case Of Difficulty.	18
Service Information.	19
Service.	19
Replacements.	21
Shipping Instructions.	21
Warranty.	22

HEATH COMPANY,
BENTON HARBOR,
MICHIGAN



DAYSTROM, INCORPORATED



SPECIFICATIONS

Power Output	Nominal rating: 250 volts DC at 100 milliamperes, ICAS (Intermittent Commercial or Amateur Service).
Power Requirements 12-Volt Operation	16 volts maximum, 12.6 volts nominal at 3 amperes for rated output.
6-Volt Operation	8 volts maximum, 6.3 volts nominal at 6.5 amperes for rated output.
Vibrator	Mallory type 1610, or equivalent.
Rectifier	Two silicon diodes in a voltage-doubler circuit.
Dimensions	4-5/8" high x 6-1/2" wide x 4-1/8" deep.
Net Weight	4-3/4 lbs.
Shipping Weight	6 lbs.

INTRODUCTION

The HEATHKIT Model GP-11 Vibrator Power Supply is a compact, dependable, low-cost source of B+ voltage, intended for use with equipment requiring up to 100 milliamperes of B+ current. Many of the low-power Amateur and Citizens Band transceivers fall into this category. It can be operated from either a 6-volt or 12-volt DC power source, such as a storage battery. Because of its

small physical size, the Power Supply is ideal for limited-space installations in cars, trucks, boats, etc. Since the Power Supply can be switched on and off remotely, it may be mounted at some convenient location away from the equipment to which it supplies B+ voltage.

CIRCUIT DESCRIPTION

To better understand how the Power Supply works, follow the circuit on the Schematic Diagram while reading this description.

DC source voltage is applied to the INPUT terminal, and via a hash filter network consisting of choke RFC1 and capacitors C1 and C2, to the vibrator. The Power Supply can be wired to operate from either a 6-volt or 12-volt DC source. In either case, the vibrator coil is operated from 6 volts. For 12-volt operation, resistor R1 is used in series with the vibrator coil to drop the voltage applied to the coil to 6 volts. For 6-volt operation, a wire is connected across resistor R1, and 6 volts is applied directly to the vibrator coil.

The vibrator acts as a mechanical switch, alternately connecting and disconnecting the voltage source to opposite ends of the transformer primary winding at a rate of approximately 115 cps. This results in a rectangular waveform which, due to the step-up effect of the transformer, appears as a high AC voltage in the secondary winding. By using different primary winding taps for 6-volt and 12-volt operation, the step-up ratio of the transformer can be changed so that the same secondary AC voltage results in either case. Buffer capacitor C6 is connected directly across the secondary winding.

AC voltage is applied from the secondary winding, through capacitor C7 to silicon diodes D1 and D2. These diodes with capacitors C7 and C8 are arranged in a half-wave voltage-doubler circuit. Choke RFC2 and capacitor C9 provide hash filtering for the B+ voltage as it is applied to the B+ output terminal.

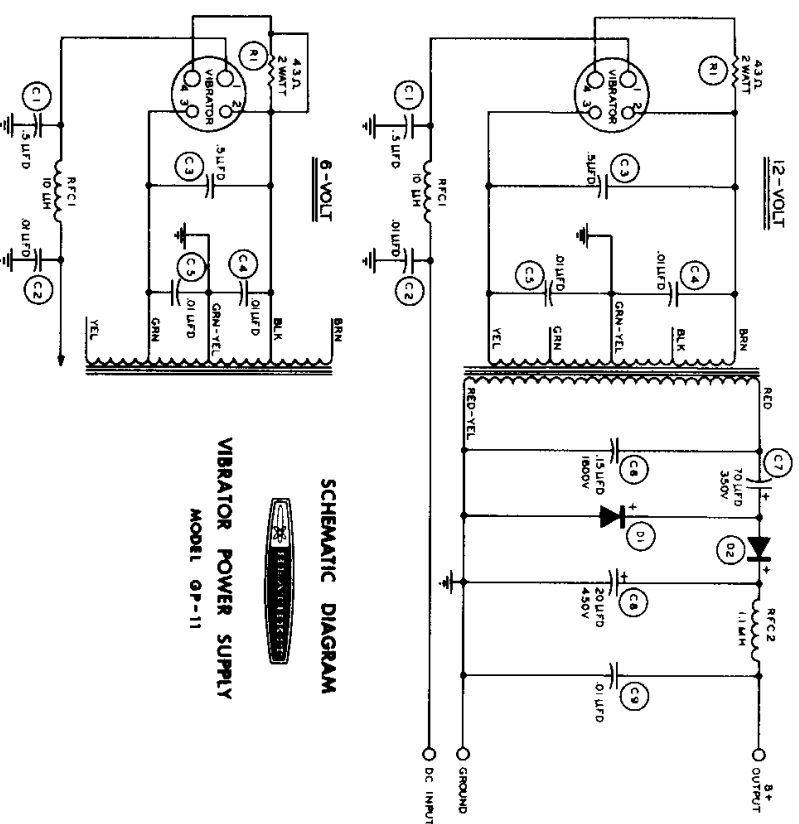

SCHEMATIC DIAGRAM
VIBRATOR POWER SUPPLY
MODEL GP-11

INITIAL TEST

Refer to Figure 1 for the following steps.

- () Connect a DC voltmeter to the B+ and GND terminals of the Power Supply. The common voltmeter test lead goes to GND. The voltmeter should be set to a high scale, capable of indicating at least 400 volts.
- () Connect a DC power source to the INPUT and GND terminals of the Power Supply. A 6-volt or 12-volt power source may be used, depending on which way your Power Supply is wired. Polarity is not important.
- () Upon connecting the power source, a slight buzzing sound should be heard and the voltmeter should indicate approximately +350 to 400 volts DC. Leave the Power Supply on for two or three minutes. The voltage indication on the meter should not change appreciably in this time. If excessive heating or any other unusual condition is noticed, immediately disconnect the power source and refer to the In Case Of Difficulty section of the manual.
- () If operation seems satisfactory, first disconnect the power source and then the DC voltmeter from the Power Supply.
- () Momentarily short between the B+ and GND terminals of the Power Supply. This will discharge the capacitors, thus eliminating the possibility of being shocked when handling the Power Supply during installation.

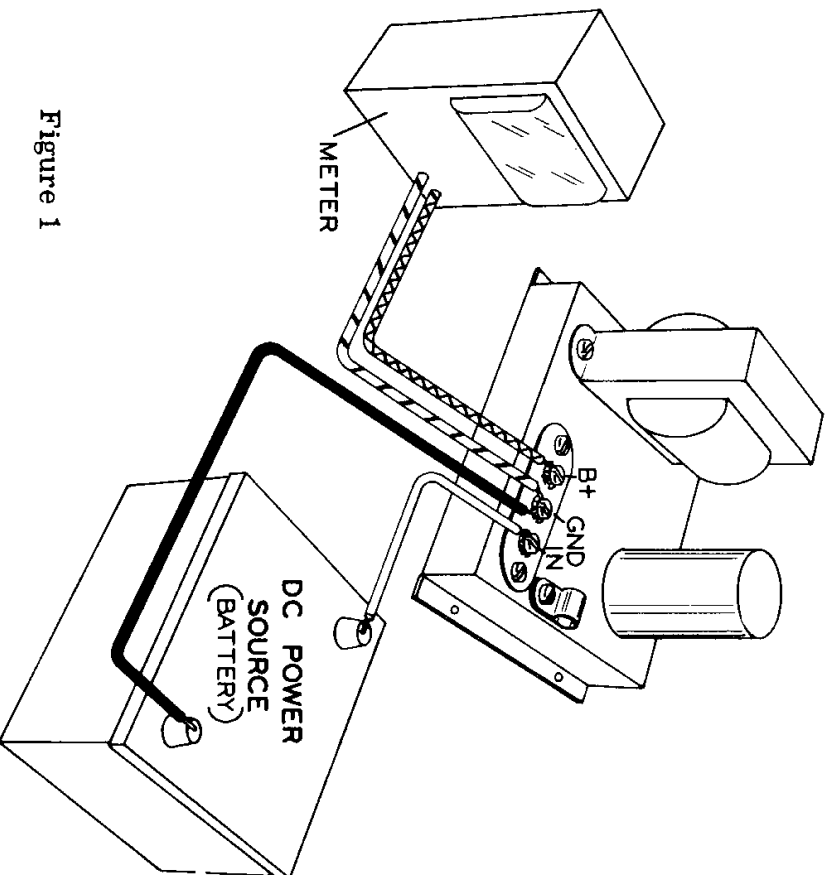

Figure 1

NOTE: The cover will be secured in place after the Power Supply is installed.

INSTALLATION

MOUNTING

The mounting location chosen for the Power Supply should be sheltered from rain and, preferably, should be free of excessive dust circulation. The Power Supply may be mounted in any position. However, the screw terminal strip and both ends of the chassis should be accessible.

Mounting holes are provided in the ends of the bottom plate. Wood screws, sheet metal screws, or nuts and bolts may be used, depending on the type of mounting surface.

WIRING

Figure 2 shows the wiring needed to use the Power Supply. Note that, in this case, the DC power source is turned on and off remotely with an external switch. If desired, a switch could be used in the equipment connected to the Power Supply. Only three wires are needed to use the Power Supply. Use #16 or larger wire for the INPUT and GND. Keep these wires as short as possible. For safety reasons, a fuse should be used in series with the INPUT wire as shown in Figure 2.

The wires running to the screw terminals should be secured in the plastic clamp adjacent to the screw terminal strip.

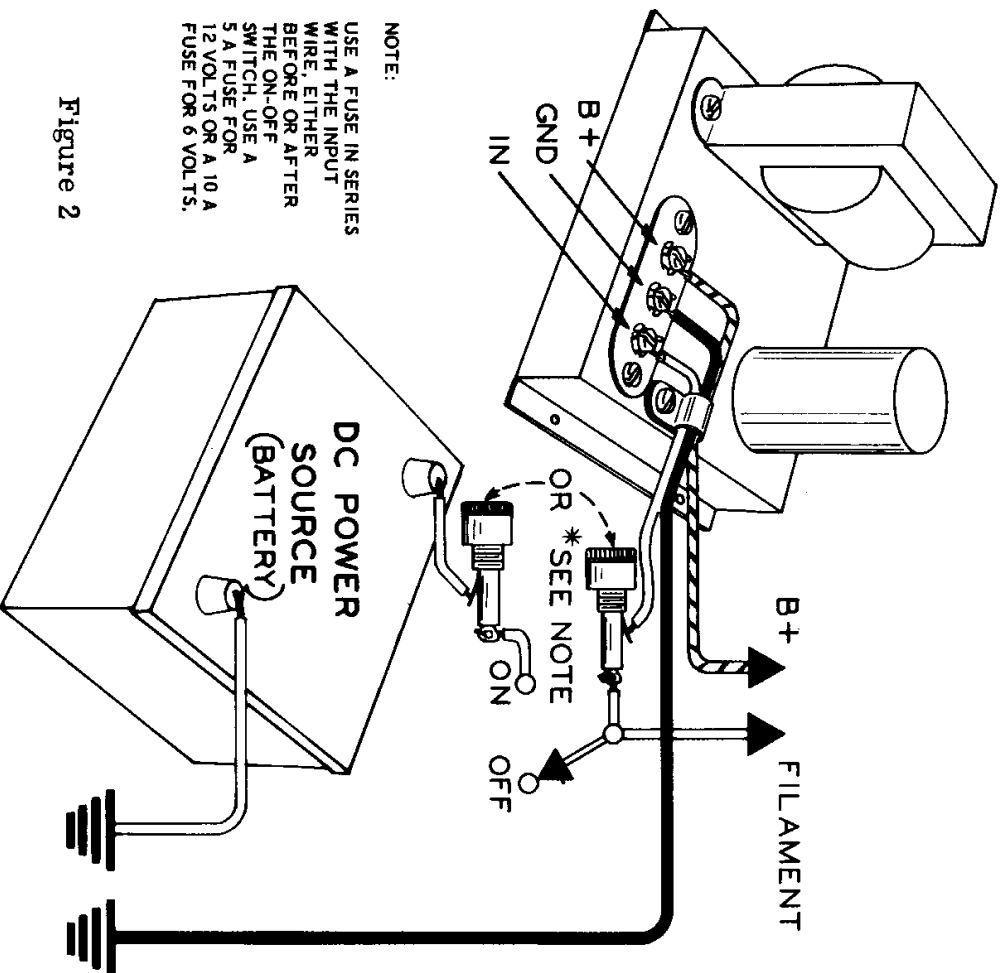

Figure 2



COVER INSTALLATION

Install the cover as shown in Figure 3. Use two 6-32 x 1/4" screws, one for each end of the cover. Each screw should be placed through its hole in the cover and then tightened into the speednut mounted on the chassis. The slot of the cover should fit over the wires running to the Power Supply.

INPUT VOLTAGE CONVERSION

The Power Supply can be changed from 12-volt to 6-volt operation, or vice versa, as follows:

12-VOLT TO 6-VOLT CONVERSION (Refer to Figure 4).

- () Clip out the bare wires presently connected from lugs 2 and 3 of vibrator socket F to lugs 1 and 5 of terminal strip E.
- () Connect a bare wire from lug 2 of vibrator socket F to lug 2 of terminal strip E. Solder both connections.
- () Connect a bare wire from lug 3 of vibrator socket F to lug 4 of terminal strip E. Solder both connections.
- () Connect a 1-3/4" length of hookup wire between lugs 4 and 2 of vibrator socket F. Solder both connections. This wire is intentionally connected across the 43 Ω resistor to facilitate 6-volt operation.

This completes the 12-volt to 6-volt conversion.

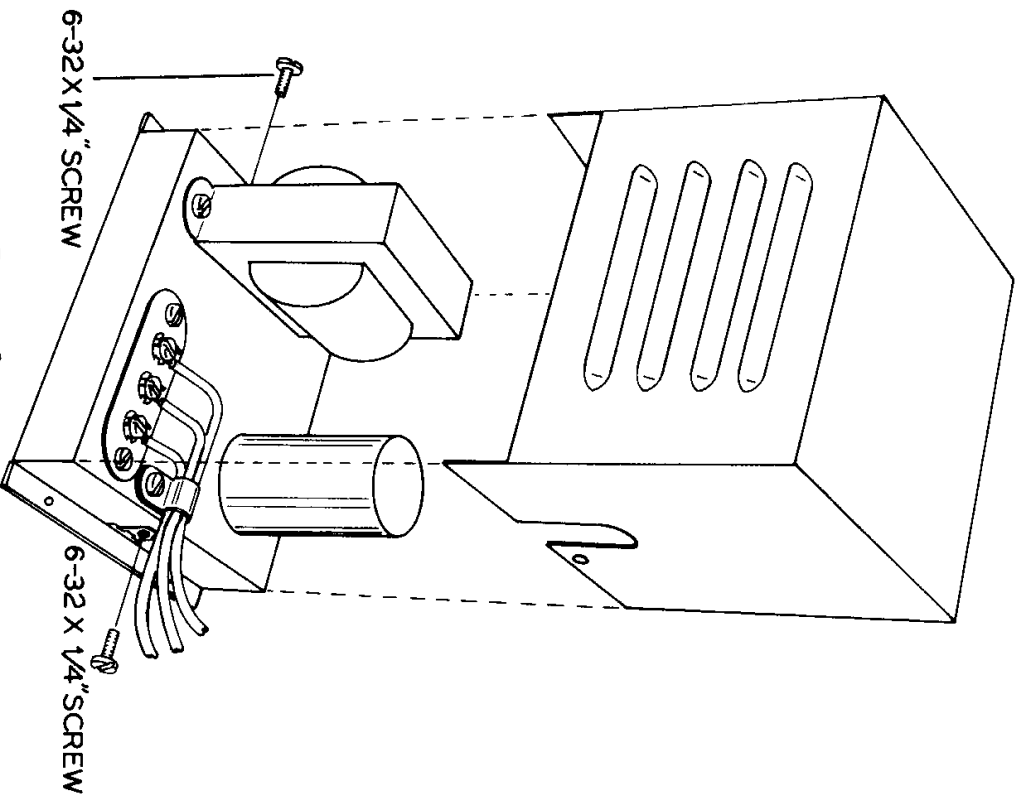

Figure 3

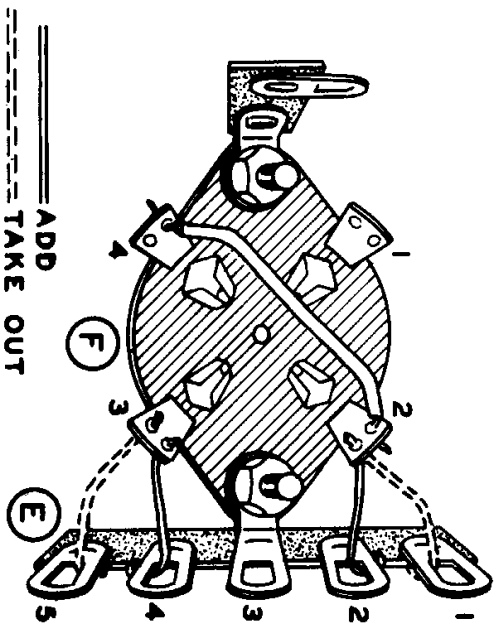

Figure 4

6-VOLT TO 12-VOLT CONVERSION (Refer to Figure 5).

- () Clip out the bare wires presently connected from lugs 2 and 3 of vibrator socket F to lugs 2 and 4 of terminal strip E.
- () Clip out the hookup wire presently connected between lugs 2 and 4 of vibrator socket F.

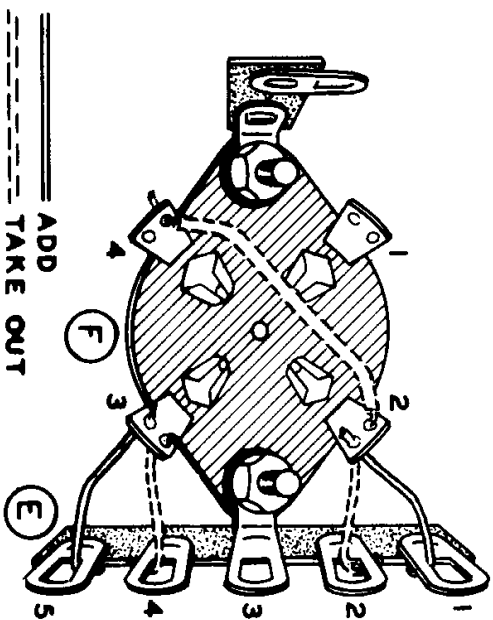

Figure 5

- () Connect a bare wire from lug 2 of vibrator socket F to lug 1 of terminal strip E. Solder both connections.
 - () Connect a bare wire from lug 3 of vibrator socket F to lug 5 of terminal strip E. Solder both connections.
- This completes the 6-volt to 12-volt conversion.



IN CASE OF DIFFICULTY

1. Recheck the wiring. Trace each lead in colored pencil on the Pictorial as it is checked. It is frequently helpful to have a friend check your work. Someone who is not familiar with the unit may notice something consistently overlooked by the constructor.
2. It is interesting to note that about 90% of the kits that are returned for repair, malfunction due to poor connections and soldering. Therefore, many troubles can be eliminated by reheating all connections to make sure that they are soldered as illustrated in the Figures found in the Soldering Techniques section of this manual. Where several leads connect to a terminal, make sure all are properly soldered.
3. Check the values of the component parts. Be sure that the proper part has been wired into the circuit, as shown in the
4. pictorial diagrams and as called out in the wiring instructions.
5. Check for bits of solder, wire ends or other foreign matter which may be lodged in the wiring beneath the chassis.
6. If there is no buzzing sound from the vibrator, check the input connections and primary circuit wiring.
7. If there is a buzzing sound from the vibrator, but no B+, check the secondary circuit for AC voltage (around 100 volts, depending on meter). Check the electrolytic capacitors and diodes for correct polarity, and check RFC2 for continuity.
7. A review of the Circuit Description will prove helpful in indicating where to look for trouble.