



Radio Mods Manuals

IC-22U IC-24^{E/G}

144MHz FM TRANSCEIVER

INSTRUCTION MANUAL

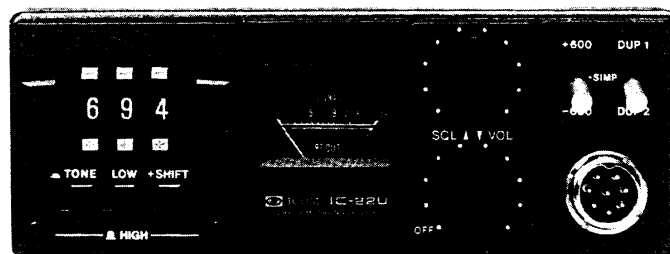

TABLE OF CONTENTS

I. SPECIFICATIONS	1
II. DESCRIPTION	2
III. INSTALLATION	3
IV. CONTROL FUNCTIONS.....	6
V. OPERATION	9
VI. INSIDE VIEW	11
VII. THEORY OF OPERATION	13
VIII. TROUBLE SHOOTING.....	20
IX. VOLTAGE CHARTS.....	22
X. BLOCK DIAGRAM	24
XI. P.C. BOARD LAYOUT.....	SEPARATE
XII. SCHEMATIC DIAGRAM.....	SEPARATE

SECTION I SPECIFICATIONS

GENERAL

Numbers of semi-conductors	:	Transistor	33 (IC-24G: 34)
		FET	6
		IC	10 (IC-24G: 12)
		Diode	42 (IC-24G: 44)
Frequency coverage	:	IC-22U	144.000 ~ 147.995MHz
		IC-24E	144.000 ~ 145.995MHz
		IC-24G	144.000 ~ 145.9875MHz
Frequency resolution	:	10KHz steps (IC-24G: 25KHz steps) +5KHz shifts with SHIFT switch depressed (IC-24G: +12.5KHz shifts)	
Frequency Control	:	Thumbwheel switched digital PLL synthesizer	
Usable conditions	:	Temperature: $-10^{\circ}\text{C} \sim 60^{\circ}\text{C}$ ($14^{\circ}\text{F} \sim 140^{\circ}\text{F}$) Operationable time: continuous	
Frequency stability	:	Within $\pm 1.5\text{KHz}$.	
Antenna impedance	:	50 ohms unbalanced	
Power supply requirement	:	13.8V DC $\pm 15\%$ (negative ground) 2.5A Max.	
Current drain	:	Transmitting	
		HIGH (10W)	Approx. 2.3A
		LOW (1W)	Approx. 0.9A
		Receiving	
		At max audio output	Approx. 0.5A
		Squelched	Approx. 0.3A
Dimensions	:	156mm (W) x 58mm (H) x 218mm (D)	
Weight	:	Approx. 1.7kg	

TRANSMITTER

Output power	:	10W (HIGH), 1W (LOW)
Emission mode	:	16F_3
Modulation system	:	Variable reactance frequency modulation
Max. frequency deviation	:	$\pm 5\text{KHz}$
Spurious emission	:	More than 60dB below carrier
Microphone	:	1.3K ohm dynamic microphone with built-in preamplifier and push-to-talk switch
Operating mode	:	Simplex, Duplex ($\pm 600\text{KHz}$ from receive frequency)
Tone Burst	:	$1750\text{Hz} \pm 0.1\text{Hz}$ (IC-22U: Not installed)

RECEIVER

Receiving system	:	Double-conversion superheterodyne
Modulation acceptance	:	16F_3
Intermediate frequency	:	1st: 16.9MHz 2nd: 455KHz
Sensitivity	:	More than 30dB S+N+D/N+D at $1\mu\text{V}$ Less than $0.6\mu\text{V}$ for 20dB Noise quieting
Squelch sensitivity	:	Less than $0.4\mu\text{V}$
Spurious response rejection ratio	:	More than 60dB
Selectivity	:	More than $\pm 7.5\text{KHz}$ at -6dB point Less than $\pm 15\text{KHz}$ at -60dB point
Audio output power	:	More than 1.5W at 10% distortion
Audio output impedance	:	8 ohms

SECTION II DESCRIPTION

This transceiver is a thumbwheel switched PLL synthesizer transceiver and is extremely rugged and completely solid state. State of the art devices such as Integrated Circuits, Field Effect Transistors, etc., and advanced PLL (Phase-Locked-Loop) technology are engineered into a tight-knit straightforward electronic design throughout both transmitter and receiver. Reliability, low current demand, excellent performance and ease of operation are the net result.

The RF amplifier and first mixer circuits using MOS FET's, and high-Q helical cavity resonators provide excellent Cross Modulation and Two-Signal Selectivity characteristics. The IC-22U/24E/24G has excellent sensitivity demanded especially for mobile operation, PLL controlled first and crystal controlled second local oscillators produce excellent stability, and with Crystal and Ceramic Filters having high shape factors, exceptional selectivity.

The transmitter section will produce a minimum of 10 Watts RF output. Again, a Phase-Locked-Loop is employed for initial frequency stability. 800 channels (IC-24E: 400, IC-24G: 160 channels) and various Duplex capabilities are provided for operating convenience and versatility. High-Q stages provide minimum interstage spurious emission. A low-pass filter is placed at the output to further insure undesirable frequency products not being emitted. Final PA transistor protection circuit is incorporated in the final circuitry. A new design heatsink is employed to increase final amplifier reliability.



SECTION III INSTALLATION

UNPACKING

Carefully remove your transceiver from the packing carton and examine it for signs of shipping damage. Should any be apparent, notify the delivering carrier or dealer immediately, stating the full extent of the damage. It is recommended you keep the shipping cartons. In the event storage, moving, or reshipment becomes necessary, they come in handy. Accessory hardware, cables, etc., are packed with the transceiver. Make sure you have not overlooked anything.

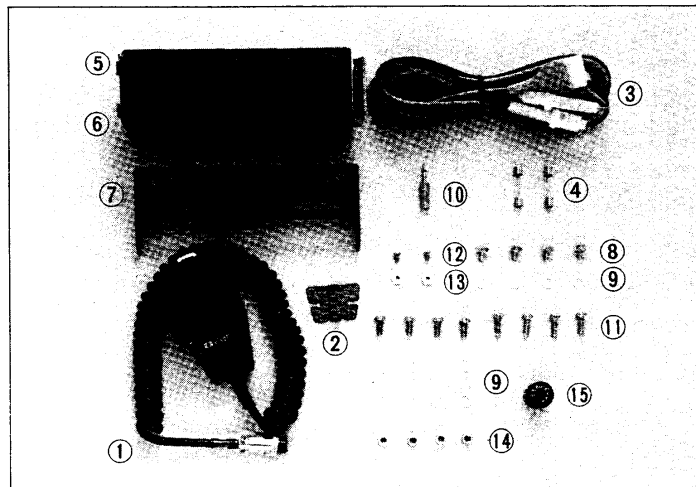

1. Microphone (dynamic type)	1	9. Flat washers	12
2. Microphone hook	1	10. Plug for speaker	1
3. Power cord.	1	11. Mounting screws	8
4. Spare fuses (5A)	2	12. Screws for additional bracket.	2
5. Installing holder A.	1	13. Flat head screw's nuts	2
6. Installing holder B.	1	14. Mounting screw's nuts	4
7. Installing angle joint.	1	15. 9 Pin MT plug.	1
8. Gimp screws.	4		

LOCATION

Where you place the transceiver in your automobile is not critical and should be governed by convenience and accessibility. Since the unit is so compact, many mobile possibilities present themselves. In general, the mobile mounting bracket will provide you with some guide as to placement. Any place where it can be mounted with metal screws, bolts, or pop-rivets will work. For fixed station use, a power supply should be designed to produce 3 amps for the transceiver.

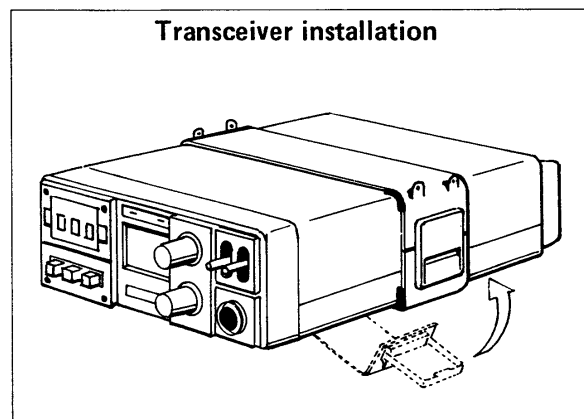
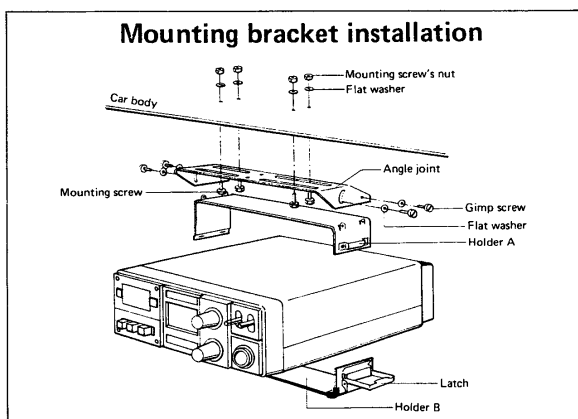

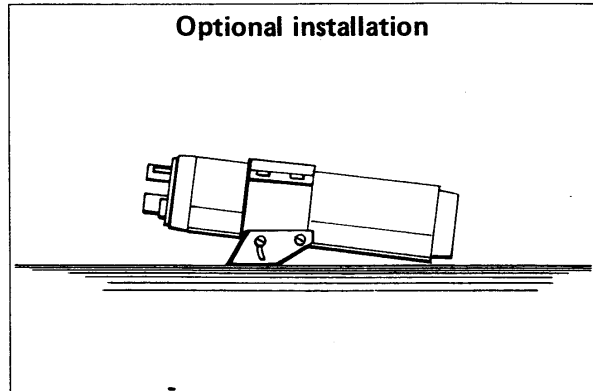
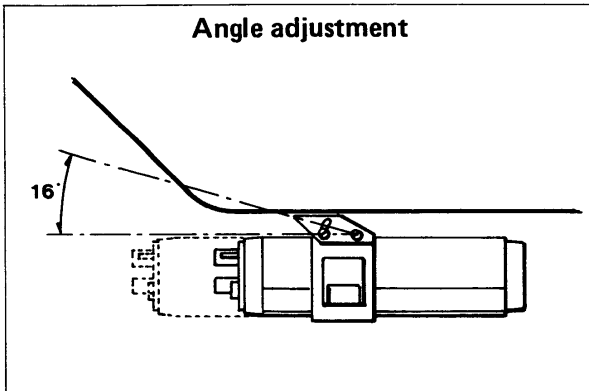

POWER REQUIREMENTS

The transceiver is supplied ready to operate from any regulated 13.8V DC, 3 ampere negative ground source. An automobile 12 volt, negative ground, system is usually more than adequate. Some note must be taken, however, of the condition of the vehicle's electrical system. Items such as low battery, worn generator/alternator, poor voltage regulator, etc., will impair operation of your transceiver as well as the vehicle. High noise generation or low voltage delivery can be traced to these deficiencies. If an AC power supply is used with your transceiver, make certain it is adequately regulated for both voltage and current. Low voltage while under load will not produce satisfactory results from your transceiver. Receiver gain and transmitter output will be greatly impaired. Caution against catastrophic failure of the power supply should be observed.

CAUTION: Excessive Voltage (above 15VDC) will cause damage to your transceiver. Be sure to check source voltage before plugging in the power cord.

Included with your transceiver is a DC power cable with plug attached. The Red Wire is positive (+), the Black, negative (-). If your mobile installation permits, it is best to connect these directly to the battery terminals. This arrangement eliminates random noise and transient spikes sometimes found springing from automotive accessory wiring. If such an arrangement is not possible, then any convenient B+ lead in the interior of the vehicle and the negative frame can be utilized. Remember, the unit operates on a negative ground system only; it cannot be used in a positive ground automobile. After making your connections, simply insert the plug into your transceiver.

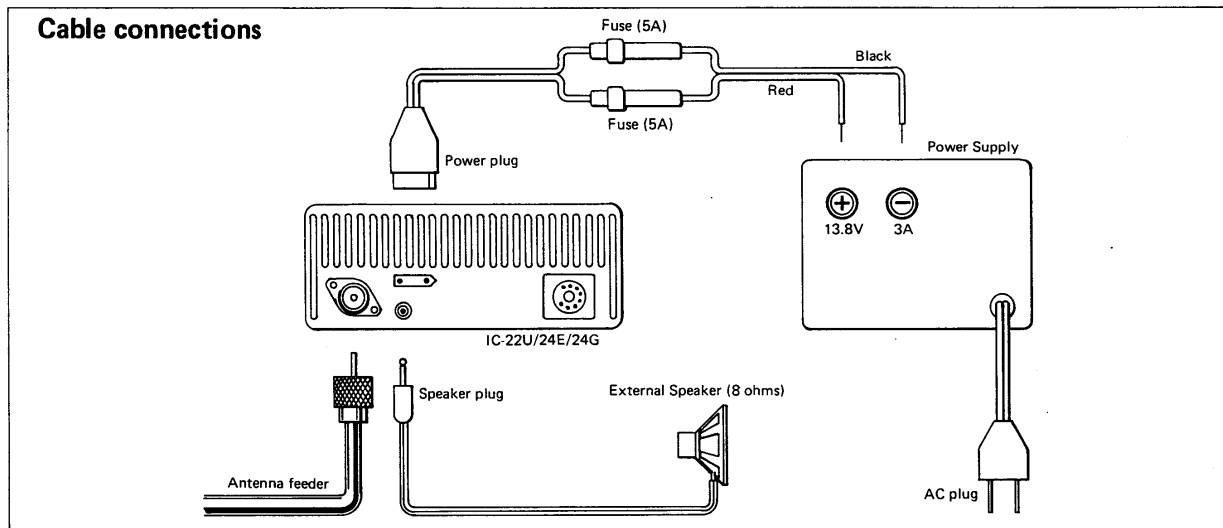

ANTENNA

The most important single item that will influence the performance of any communication system is the antenna. For that reason, a good, high-quality, gain antenna of 50 ohms impedance is recommended, fixed or mobile. In VHF as well as the low bands, every watt of ERP makes some difference. Therefore, 10 watts average output plus 3dB of gain antenna equals 20 watts ERP, presuming low VSWR of course. The few more dollars invested in a gain type antenna is well worth it. When adjusting your antenna, whether mobile or fixed, by all means follow the manufacturer's instructions. There are some pitfalls to be aware of. For example, do not attempt to adjust an antenna for lowest VSWR when using a diode VSWR meter not engineered for VHF applications. Such readings will invariably have an error of 40% or more. Instead, use an in line watt meter similar to the Drake WV-4, Bird Model 43 or Sierra Model 164B with VHF cartridge. Further, when adjusting a mobile antenna, do so with the motor running preferably above normal idling speed. This will insure proper voltage level to the transceiver.

The RF coaxial connector on the rear chassis mates with a standard PL-259 connector. Some models may have metric threads. In any event, the RF connector will mate with almost any PL-259 connector if care is taken to seat them properly.

MICROPHONE

A high quality dynamic microphone with built-in preamplifier is supplied with your transceiver. Merely plug it into the proper receptacle on the front panel. Should you wish to use a different microphone, make certain it has a proper preamplifier. Particular care should be exercised in wiring also; as the internal electric switching system is dependent upon it. See the schematic for the proper hook up.

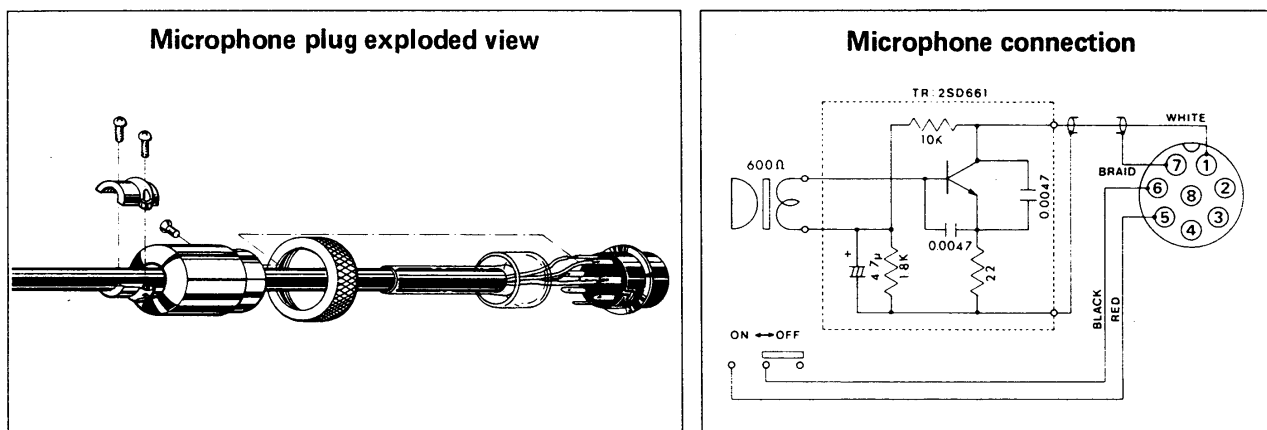

EXTERNAL SPEAKER

An external speaker jack and plug is supplied with your unit in the event another speaker is desirable. The external speaker impedance should be 8 ohms, and when used, will disable the internal speaker. An 8 ohm headset can be utilized as well.

SECTION IV CONTROL FUNCTIONS

FRONT PANEL

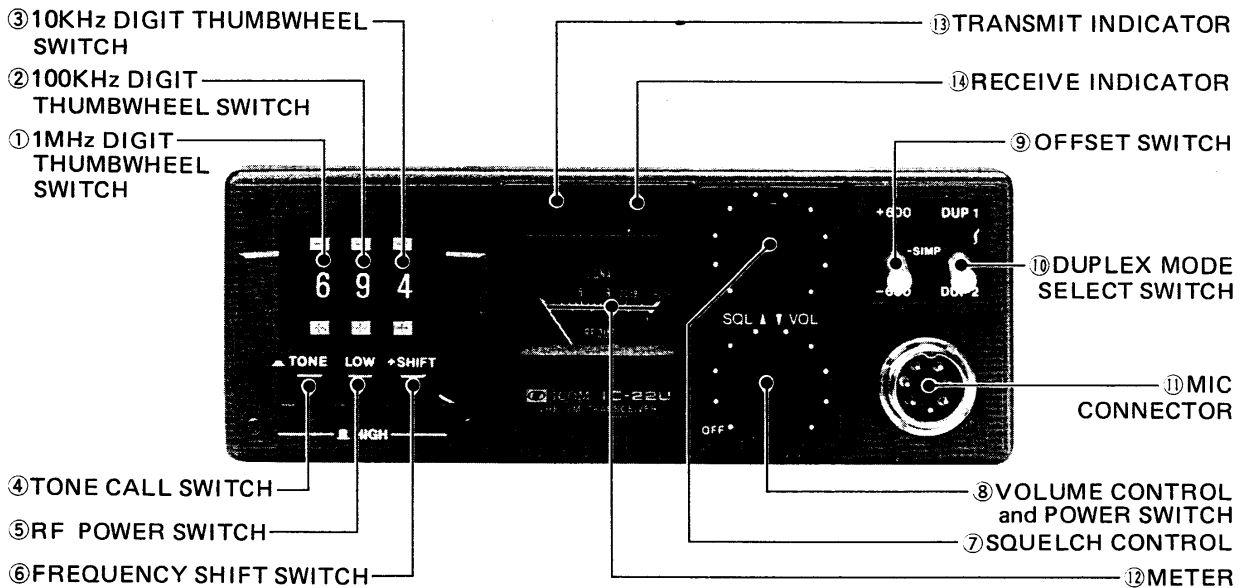

1. 1MHz THUMBWHEEL SWITCH

Sets 1MHz digit of the desired operating frequency. When you set a digit of a frequency that is out of the band, the set will work as follows:

Digit	Actual Working frequency band	
	IC-22U	IC-24E/24G
0	144MHz	144MHz
1	145	145
2	146	144
3	147	145
4	144	144
5	145	145
6	146	144
7	147	145
8	144	144
9	145	145

Push the ⊕ button to increase the digit, and the ⊖ button to decrease.

2. 100KHz THUMBWHEEL SWITCH

Sets 100KHz digit of the desired operating frequency.

3. 10KHz THUMBWHEEL SWITCH

Sets 10KHz digit of the desired operating frequency.

NOTE: IC-24G indicates the operating channel number with ② and ③ thumbwheel switches.
(Refer to page 18.)

4. TONE CALL SWITCH

Most repeaters require a 1750Hz Tone-burst for initial access. Depressing the Tone Call Switch for the required period for a repeater, puts the set in the transmit mode and the tone burst generator actuates and you can access the repeater.

When the Tone Call unit is not installed, this switch can be used for a momentary transmit switch.

5. RF POWER

This switch is a push-lock type switch which controls the RF output power. When the switch is pushed in and locked, the RF output power is reduced to 1 watt. When the switch is pushed again and released, the RF output power returns to 10 watts.

6. FREQUENCY SHIFT SWITCH

When the desired operating frequency has a 5KHz digit, set this switch to the in position, and add 5KHz to the indicated frequency on the thumbwheel switches.

(IC-24G: This switch shifts 12.5KHz, i.e., exact middle point to the next upper channel of the indicated channel.)

7. SQUELCH CONTROL

Sets the squelch threshold level. To turn OFF the squelch function, rotate this control completely counterclockwise. To set the threshold level higher, rotate the control clockwise.

8. VOLUME CONTROL and POWER SWITCH

When the control is turned completely counterclockwise, the power is OFF. By turning the control clockwise beyond the "click", the unit is turned ON and the audio level increases by further rotating it clockwise.

9. OFFSET SWITCH

Selects Duplex or Simplex operation, and sets the transmitting frequency (or receiving frequency) 600KHz above or 600KHz below the indicated frequency for Duplex operation.

10. DUPLEX MODE SELECT SWITCH

Selects whether the transmitting frequency is offset (+600KHz or -600KHz) or the receiving frequency is offset from the displayed frequency.

11. MIC CONNECTOR

Connect the supplied microphone to this jack. If you wish to use a different microphone, refer to the drawing on page 5.

12. METER

The numbers on the S-meter represent S1 through S9 and 20 and 60dB over S9. The RF output level meter functions only as a relative output meter and does not indicate the wattage. These functions are switched automatically when T/R switching is made.

13. RECEIVE INDICATOR

Illuminates when the squelch is opened in the receive mode.

14. TRANSMIT INDICATOR

Illuminates in the transmit mode.

REAR PANEL

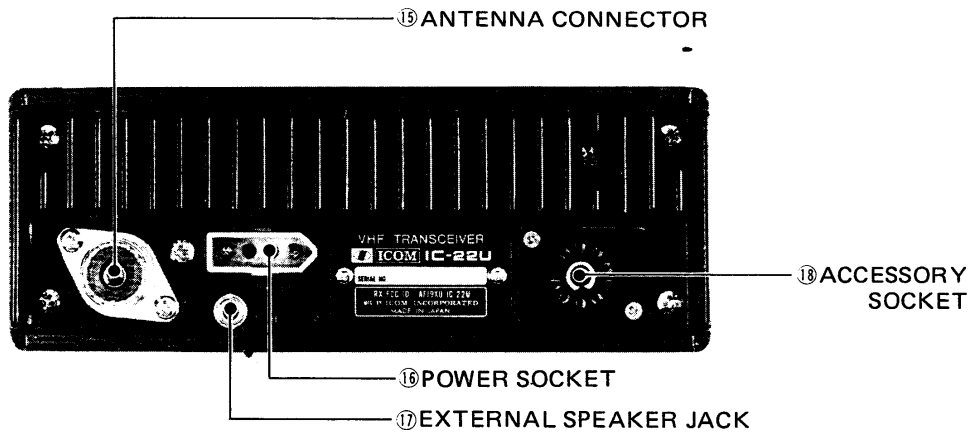

15. ANTENNA CONNECTOR

This is used to connect the antenna to the set. Its impedance is 50 ohms and connects with a PL-259 connector.

16. POWER SOCKET

Connect the supplied power cord to this socket.

17. EXTERNAL SPEAKER JACK

When an external speaker is used, connect it to this jack. Use a speaker with an impedance of 8 ohms. When the external speaker is connected the built-in speaker does not function.

18. ACCESSORY SOCKET

This terminal is available for your personal use, such as for adding accessory circuits, etc., if desired.

SECTION V OPERATION

INITIAL PREPARATION

Make sure the VOLUME Control and POWER Switch is in the OFF position, then connect the power supply cord to the power connector. The red lead should be connected to the positive terminal of the power source and the black lead to the negative terminal. In the event that these leads are improperly connected, the transceiver will not function. Reversing polarity will blow out the fuse in the power supply cord due to actuation of the protection circuit.

Connect the microphone to the MIC Connector.

Connect the antenna to the Antenna Connector. Make sure the coax line is of the correct impedance (50 ohms) and is neither shorted nor open.

RECEIVING

Set the controls and switches as follows:

- ⑦ SQUELCH CONTROL Completely counterclockwise
- ⑧ VOLUME CONTROL Completely counterclockwise
- ⑨ OFFSET SWITCH SIMP
- ①~③ THUMBWHEEL SWITCHES and ⑥ FREQUENCY SHIFT SWITCH Desired frequency
(Others may be at any position or setting.)

Turn the ⑧ VOL control clockwise (it will "click" ON) and the meter will illuminate.

Turn the VOL control clockwise to a comfortable audio level.

If no signal can be heard but only noise, turn the ⑦ SQL control clockwise until the noise from the speaker stops and set it just below this threshold. (When adjusting the SQL setting, if some communication signals can be heard, turn the thumbwheel switch either direction and set it where only noise can be heard.) Your transceiver will now remain silent until an in-coming signal is received which opens the squelch. If the squelch is unstable due to the reception of weak or mobile stations, adjust the squelch control further until the proper threshold is obtained.

TRANSMITTING

Set the controls and switches as follows:

- ⑨ OFFSET SWITCH (see below)
- ⑩ DUPLEX MODE SELECT SWITCH (see below)
- ⑤ RF POWER SWITCH HIGH
- ①~③ THUMBWHEEL SWITCHES and ⑥ FREQUENCY SHIFT SWITCH Desired frequency

For simplex operation, set ⑨ OFFSET SWITCH at the SIMP position, making ⑩ DUPLEX MODE SELECT SWITCH nonfunctional.

For repeater operation, set ⑨ OFFSET switch and ⑩ DUPLEX MODE SELECT SWITCH according to repeater's input/output frequencies.

The relationship of the OFFSET switch and DUPLEX MODE SELECT switch is as follows:

DUPLEX MODE, SELECT SWITCH	OFFSET SWITCH	RECEIVE FREQUENCY	TRANSMIT FREQUENCY
DUP 1	+600	(Set frequency) +600KHz	Set frequency
DUP 1	-600	(Set frequency) -600KHz	Set frequency
DUP 2	+600	Set frequency	(Set frequency) +600KHz
DUP 2	-600	Set frequency	(Set frequency) -600KHz
(any)	SIMP	Set frequency	Set frequency

NOTE: IC-24G's FREQUENCY SHIFT switch acts in the SIMPLEX mode and +600KHz DUPLEX mode only.

If the lower output power (1W) is sufficient, set ⑤ RF POWER Switch to the LOW (in) position.

Depress the PTT (push to talk) Switch on the microphone and the transceiver will transmit. At the same time the TRANSMIT indicator will be illuminated red and the meter will provide an indication of relative power output of the transmitter. Speak into the microphone with your normal speech level for the proper microphone level.

If you need a tone-burst for initial access of the repeater, depress the ④ TONE CALL Switch for the required period. (Tone-burst periods vary individually from 100 milliseconds to 2 seconds.)

SECTION VI INSIDE VIEW

MAIN UNIT SIDE

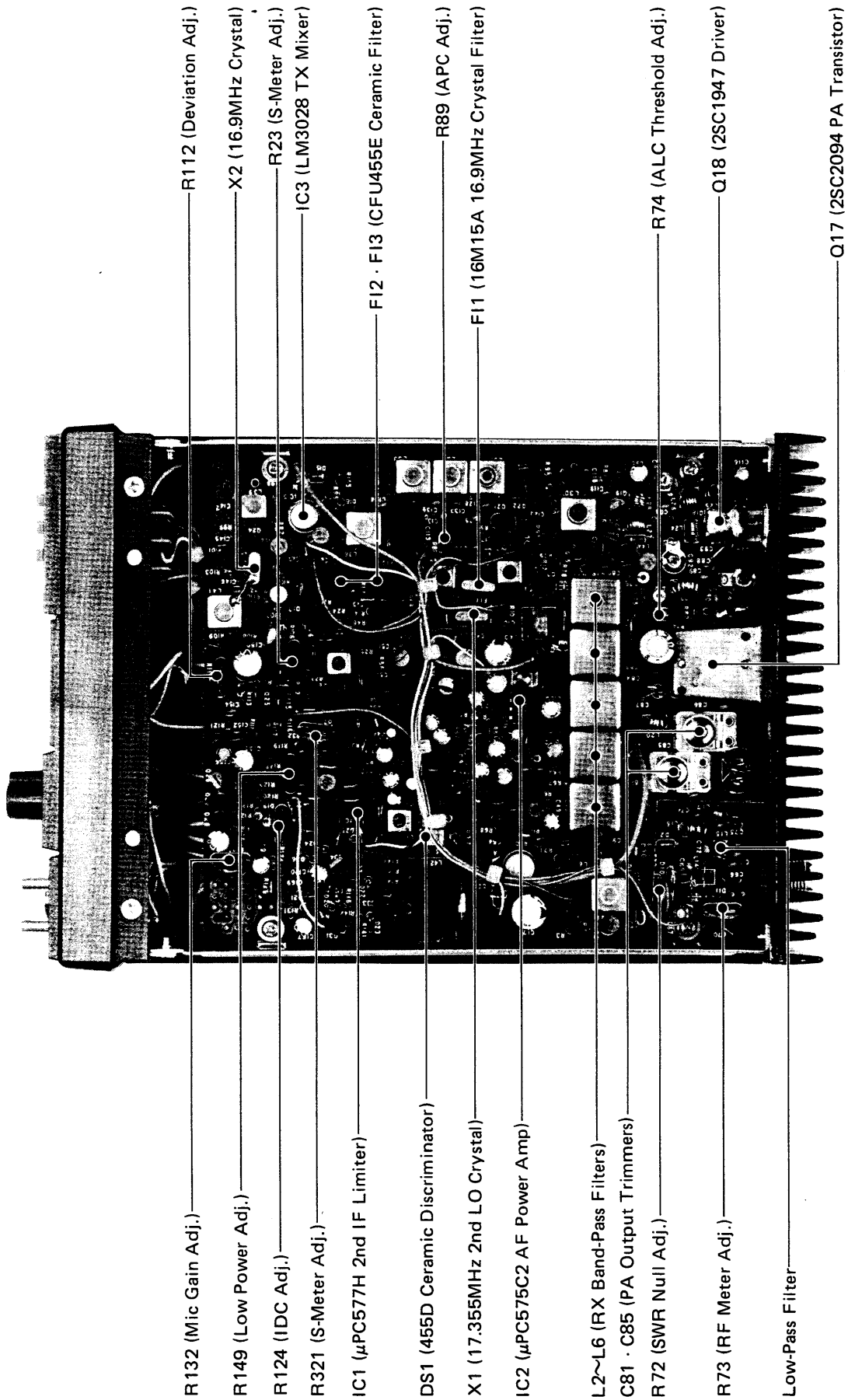

- R132 (Mic Gain Adj.)
- R149 (Low Power Adj.)
- R124 (IDC Adj.)
- R321 (S-Meter Adj.)
- IC1 (μ PC577H 2nd IF Limiter)
- DS1 (455D Ceramic Discriminator)
- X1 (17.355MHz 2nd LO Crystal)
- IC2 (μ PC575C2 AF Power Amp)
- L2~L6 (RX Band-Pass Filters)
- C81 · C85 (PA Output Trimmers)
- R72 (SWR Null Adj.)
- R73 (RF Meter Adj.)
- Low-Pass Filter
- R112 (Deviation Adj.)
- X2 (16.9MHz Crystal)
- R23 (S-Meter Adj.)
- IC3 (LM3028 TX Mixer)
- F12 · F13 (CFU455E Ceramic Filter)
- R89 (APC Adj.)
- F11 (16M15A 16.9MHz Crystal Filter)
- R74 (ALC Threshold Adj.)
- Q18 (2SC1947 Driver)
- Q17 (2SC2094 PA Transistor)

PLL UNIT SIDE

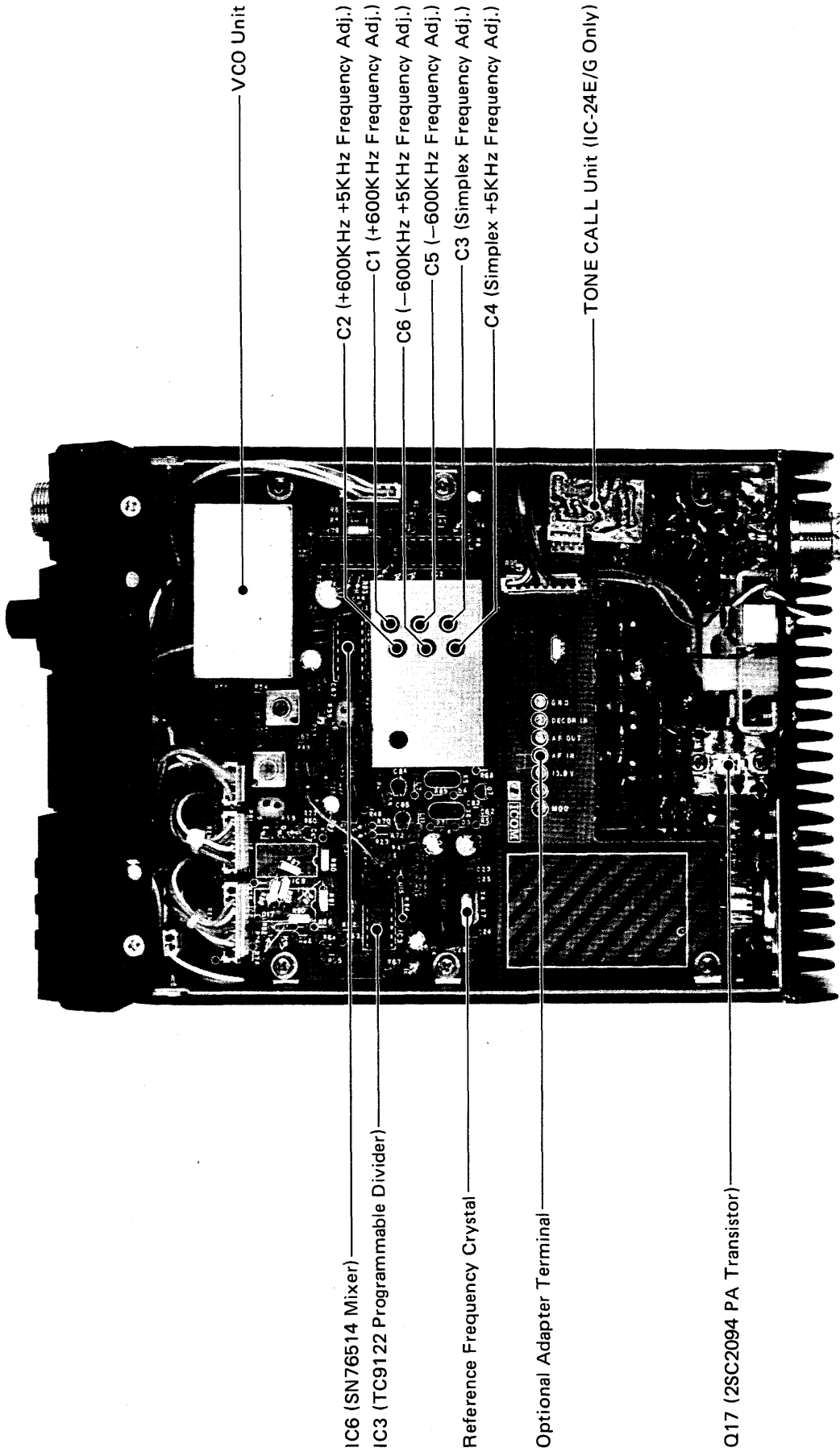

SECTION VII THEORY OF OPERATION

GENERAL

The receiver is a double superheterodyne, with a first intermediate frequency of 16.9MHz and a second intermediate frequency of 455KHz. A digital phase-locked loop (PLL) circuit is used as the first local oscillator, and since the 127MHz signals are oscillated fundamentally, spuriousness is held to a minimum.

Frequency setting is effected simply by thumbwheel switches which put out BCD codes.

Outstanding characteristics are ensured by use of MOS FETs for the RF amplifier and first mixer, a 5-stage helical cavity filter in the RF circuit, a monolithic crystal filter in the first IF circuit, and 2 ceramic filters in the second IF circuits.

The transmitter uses a crystal oscillator to produce the 16.9MHz signals which are direct-frequency modulated. These signals are mixed with the 127MHz signals from the PLL circuit which is the same as the first local oscillator of the receiver, and amplified to provide a 144MHz band output.

RECEIVER CIRCUITS

Antenna Switching Circuit

Signals from the antenna pass through transmit-receive switching diodes D1, D2 and D30 (1SS55s) and after amplification by RF amplifier Q2 (3SK74) are applied to the first gate of the first mixer Q3 (3SK74).

When the switching circuit is set at "receive" the switch control transistor Q1 (2SA639) is turned on by R +9V, and as the forward voltage is now applied to diodes D1, D2 and D30, signals from the antenna pass through the diodes and are fed to Q2.

During transmission, R +9V is turned off, Q1 is turned off, and forward voltage across D1, D2 and D30 is terminated. Reverse voltage due to transmission output, is applied and so D1, D2 and D30 are turned off, preventing the transmitter output from entering the receiver section.

Radio Frequency Circuit

The output of the RF amplifier, Q2, is fed to a band-pass filter, consisting of a 5-stage helical cavity filter, and serves to reduce interference or other problems caused by strong out-of-band signals.

Receive signals are converted to the first intermediate frequency, 16.9MHz, at the second gate of first mixer Q3, to which 127MHz first local oscillator signals from the PLL unit are supplied via the local oscillator transmit-receive switching diode D15 (1SS53).

Intermediate Frequency Circuits

The first IF circuit must have sharp characteristics in order to reduce interference by signals in the pass-band or secondary image frequency interference. These characteristics are ensured in the set by use of monolithic crystal filter 16M15A.

Signals that have passed through the crystal filter are supplied together with 17.355MHz signals from the second local oscillator Q9 (2SC945) to the gate of second mixer Q4 (2SK49), for conversion to the 455KHz second IF.

In the second IF amplifier, which has excellent selectivity due to 2 CFU455E ceramic filters, signals are amplified by Q5 – Q7 (2SC945s). After removal of noise and other AM components by IC1 (μ PC577H) functioning as a limiter, the signals are detected in terms of audio frequency signals by a ceramic discriminator.

This ceramic discriminator has outstanding temperature characteristics, linearity and detection sensitivity, which guarantee clear, stable reception.

Audio signals from the discriminator are divided into audio signals and noise component signals to operate the squelch circuit.

Audio Circuit

In the audio amplifier, audio signals are passed through the de-emphasis circuit consisting of R39 and C40, and amplified by Q8 (2SC1571). High frequency components are cut by a low-pass filter Q10 (2SC1571), in order to improve the signal-to-noise ratio. Then the audio signals are adjusted to a suitable level by volume control R2, amplified by AF power amplifier IC2 (μ PC575C2) to 1.5W or more, and fed to the speaker.

During transmission, positive voltage is applied via D13 (1SS53) to Pin No. 8 of IC2, and so it does not function, and there is no risk of transmission signals being supplied to the receiver circuit.

Squelch Circuit

This is a noise circuit that suppresses noise when signals enter the set. To avoid erroneous operation due to audio signals, noise components of about 25KHz are selectively amplified.

Squelch control R1 is located immediately after the discriminator, thus increasing the dynamic range of the circuit.

Noise components from squelch control R1 are amplified by Q13 and Q14 (2SC945s), rectified by D7 and D8 (1N60s), and with C56, C57, R61 and R62 ensure correct timing sequence for smooth squelching supplied to the base of squelch control transistor Q12 (2SC945).

When there are no audio signals, rectified DC voltage from D7 and D8 is applied to the base of Q12, turning it on. Since the collector of Q12 is connected to the base of AF amplifier Q8, base voltage of Q8 falls and Q8 is turned off, thus squelch action is applied, and no audio is amplified by IC2. At this time, signal lamp control transistor Q11 (2SC945) does not conduct, and so the signal lamp goes off.

When incoming signals are received, noise is suppressed, the base voltage of Q12 falls, and Q12 is turned off. Therefore, normal voltage is applied to the base of Q8, the squelch circuit is opened, and audio signals are heard from the speaker. Q11 also is turned on, and the signal lamp lights up.

The point at which squelch becomes operative (squelch threshold) is adjusted by R1.

During transmit, positive voltage is supplied through R60 to the base of Q12 and the squelch circuit is operative, so squelch action is started the moment there is switchover from transmit to receive, and no loud crackling or similar noise is heard.

TRANSMITTER CIRCUITS

16.9MHz Oscillator, Modulation Circuits

16.9MHz signals are oscillated by Q24 (2SC945) and amplified audio signals from the microphone

are supplied to varactor diode D17 (1S2688) connected in series with the crystal unit. Voltage of these signals causes the capacitance of D17 to vary, and frequency modulation is effected. Since this transceiver is a heterodyne type, any frequency deviation that occurs in this circuit appears unchanged as a frequency deviation in the 144MHz band, and so use is made of a crystal unit with special characteristics to ensure suitable frequency deviation and stability.

Mixer Circuit

These modulated signals are taken out at the emitter of Q24, and after balanced conversion by L39, are applied to transmit mixer IC3 (LM3028).

127MHz band signals from the PLL unit, which is the same as the first local oscillator of the receiver, are supplied through local oscillator transmit-receive switching diode D16 (1SS53) to IC3 and mixed with the 16.9MHz modulated signals to give signals of $127\text{MHz} \pm 16.9\text{MHz}$. As a balanced mixer is used for this mixing stage, 16.9MHz and 127MHz band signals are canceled and do not appear in the output.

Power Amplifier

The signals are further passed through a concentrated band-pass filter, to produce signals in the 144MHz band only, and then amplified by Q22 (3SK74), Q19 (2SC2053), Q18 (2SC1947), and Q17 (2SC2094), to 10 watts or more.

Since this output includes harmonics, it is passed through 2 Chebyshev sections, and 1 constant-k section low-pass filter, to attenuate harmonics to -60dB or more.

Audio Frequency Circuit

Audio signals from the microphone are adjusted by R132, and instantaneous frequency deviation is kept below a set value by an IDC circuit consisting of Q28 (2SC1571), Q27, and Q26 (2SC945s). R124 regulates bias of Q26, and keeps the chopped waveforms symmetrical. D18 and D19 (1N60s) serve as temperature compensators for the IDC circuit.

Q25 (2SC945) is an active low-pass filter which cuts out harmonics produced in the IDC circuit, and prevents spread of the sidebands. Output is taken out at the emitter of Q25. Maximum frequency deviation is adjusted by R112. R113 is a thermistor which minimizes frequency deviation caused by temperature variations.

Output Power Control

In the output power control circuit, a portion of the 144MHz band signals from the base of power amplifier Q17 is rectified by D12 and D29 (1SS53s), and DC-amplified by Q15 (2SK44), and Q16 (2SB562), to control the collector voltage of Q19. Adjustment of the output power is effected by changing the threshold level of D12 and varying DC output voltage from D29.

APC Circuit

In the APC (automatic protection) circuit, reflected waves are rectified by D10 (1N60) of the SWR detector, amplified by Q20 (2SC945), and Q21 (2SA1015) to bring them up to the level of Q22's source voltage. This lowers input excitation level to the power amplifier stage and reduces input power to the final stage, thus preventing damage to transistors due to high SWR. The operating point of the APC is adjusted by R89.

Meter Circuit

The meter functions as an S meter which indicates received signal strength during reception, and output power level during transmission.

During reception, the meter indicator needle is caused to move by a portion of the IF signals taken from the collector of the second IF amplifier Q7 and rectified by D4 (1N60). Meter indicator deflection can be adjusted by altering gain of the second IF amplifier Q5 by R23 in series with the by-pass capacitor of the emitter of Q5.

During transmission, the meter indicator is deflected as D11 (1N60) in the SWR detector rectifies forward travelling waves. Meter indication can be adjusted by R73 so that 10W output during transmission gives 4/5 scale deflection.

Power Supply Circuit

Regardless of whether the transceiver is switched to receive mode or not, power is always supplied from a constantly activated source to the receiver AF amplifier (excluding the power amplifier circuit), and PLL circuit. This power source supplies current through R142, D20 (1SS53) and zener diode D21 (XZ092), producing a regulated voltage of about 9.2V. This corresponds to the reference voltage of D21's cathode, and is applied to the base of Q31 (2SD468), resulting in a regulated voltage of about 9V which is taken out at the emitter of Q31.

The power source which is operative during reception supplies voltage to the RF amplifier, first and second mixers, second IF amplifier, and second local oscillator. Similar to the constantly activated source in the receive mode power circuit, current flows through R147, D27 (1SS53), and D21.

A reference voltage is supplied to the base of Q34 (2SD468) and regulated voltage is taken from the emitter of Q34. The power source which is in operation during transmit supplies power to the 16.9MHz oscillator, transmit mixer, IF amplifier, driver bias circuit, and APC control circuit. Similar to the receive mode power circuit, in the transmit mode power circuit current flows through R143, D22 (1SS53), and D21. A reference voltage is supplied to the base of Q32.

The ALC control circuit, exciting amplifier, power amplifier, and AF power amplifier are supplied directly with 13.8V DC.

If the power supply is connected with polarity reversed, the equipment is protected. Since D28 (SR10N2R) becomes forward biased, a large current flows and causes the fuse in the external power supply cord to blow.

Transmit-Receive Switching Circuit

During reception, since the microphone push-to-talk (PTT) switch is off, there is no flow of current through D24, D26 (1SS53s), receive power supply becomes operative, and receive +9V is obtained. Also, since D25 (1SS53) is off, voltage is supplied through R145 to the base of Q33 (2SC945) and turns Q33 on. The base of Q32 is connected to ground through D23 (1SS53), and so the transmit power supply is inoperative, and the transceiver is set in the receive mode.

During transmission, the PTT switch is on, Q34's base is connected to ground through D26, and output voltage of the receive power supply becomes zero. D24 connected to the emitter of Q34 rapidly discharges voltage stored in the receive circuit capacitor to prevent receiver and transmitter

from functioning simultaneously during switching. At the same time, Q33 is turned off, as its base is connected to ground through D25, and so the D21 reference voltage is applied to the base of Q32, +9V is obtained from the transmit power supply, and the transceiver will transmit.

PLL UNIT

This transceiver incorporates a phase-locked loop (PLL) circuit for both transmission and reception. A portion of the 127MHz signals produced by the VCO (voltage-controlled oscillator) is converted and divided. Then the phase of these signals is compared with that of a reference frequency of 10KHz (IC-24G: 25KHz). The phase difference results in a DC voltage which is used to control oscillation frequency of the VCO. In this manner, although the VCO is a self-oscillator, it has the same outstanding stability as a crystal oscillator.

VCO-Frequency Conversion Circuit

The VCO is a clap oscillator, using Q8 (2SK125), and oscillates in the 127MHz band. The oscillation frequency is locked by DC voltage which is supplied from the comparator to varactor diode D6 (1SV50) inserted in series with the oscillation coil.

The oscillator output is taken at the source of Q8, and passed through buffer Q9 (2SC763), Q6 (2SC763) and Q5 (2SC383) to become local oscillator signals for the receiver and the transmitter. A part of these signals is supplied to PLL mixer IC6 (SN76514), which mixes the signals with the 123MHz signals from the PLL local oscillator. The output of the mixer consists of signals whose frequency is 15MHz, or less.

The PLL local oscillator produces 41MHz signals with Q1 (2SC383), and the signals at 3 times this frequency, i.e., 123MHz, are taken from the collector of Q1.

The local oscillator has three crystals (IC-24G: five crystals), and they are switched according to operating modes per the following chart.

DUPLEX MODE SELECT SWITCH	OFFSET SWITCH	RECEIVE	TRANSMIT
(ANY)	SIMP	X2 (123.1MHz)	X2 (123.1MHz)
DUP 2	+600	X2 (123.1MHz)	X1 (123.7MHz)
DUP 2	-600	X2 (123.1MHz)	X3 (122.5MHz)
DUP 1	+600	X1 (123.7MHz)	X2 (123.1MHz)
DUP 1	-600	X3 (122.5MHz)	X2 (123.1MHz)

When the FREQUENCY SHIFT Switch is pushed, either Pin 3, 4 or 10 of IC2 in the operating crystal circuit, is turned to LOW level, and turns either D9, D11 or D13 OFF and reduces the serial capacitor of the crystal. Thus the output frequency of the local oscillator is shifted +5KHz.

IC-24G: When the FREQUENCY SHIFT Switch is pushed, the local oscillator oscillates 123.1125 MHz (X5) in the SIMPLEX mode, and 123.7125MHz (X6) in the +600 mode. Thus the operating frequency is shifted +12.5KHz.

As the converted signals from the PLL mixer IC6 are at a low level, they are amplified by IC7 (BA401), Q4 (2SC763), and fed to Pin 2 of IC3, programmable divider.

Divider Circuit

Programmable divider IC3 (TC9122) divides Q4 output at a ratio determined by BCD Code values which are fed from the thumbwheel switches.

The relationship between the operating frequency and the BCD codes is per the following chart.

OPERATING FREQUENCY	INPUT FREQUENCY of IC3	BCD VALUES (N)		
		IC-22U	IC-24E	IC-24G
144.00 ~ 144.99MHz	4.00 ~ 4.99MHz	400 ~ 499	400 ~ 499	160 ~ 199
145.00 ~ 145.99MHz	5.00 ~ 5.99MHz	500 ~ 599	500 ~ 599	200 ~ 239
146.00 ~ 146.99MHz	6.00 ~ 6.99MHz	600 ~ 699	—	—
147.00 ~ 147.99MHz	7.00 ~ 7.99MHz	700 ~ 799	—	—

IC-24G: DISPLAY/OPERATING FREQUENCY/BCD(N) CHART

DISPLAY	OPERATING FREQUENCY	BCD(N)	DISPLAY	OPERATING FREQUENCY	BCD(N)
400	144.000MHz	160	500	145.000MHz	200
401	025	161	501	025	201
402	050	162	502	050	202
403	075	163	503	075	203
404	100	164	504	100	204
405	125	165	505	125	205
406	150	166	506	150	206
407	175	167	507	175	207
408	200	168	508	200	208
409	225	169	509	225	209
410	250	170	510	250	210
411	275	171	511	275	211
412	300	172	512	300	212
413	325	173	513	325	213
414	350	174	514	350	214
415	375	175	515	375	215
416	400	176	516	400	216
417	425	177	517	425	217
418	450	178	518	450	218
419	475	179	519	475	219
420	500	180	520	500	220
421	525	181	521	525	221
422	550	182	522	550	222
423	575	183	523	575	223
424	600	184	524	600	224
425	625	185	525	625	225
426	650	186	526	650	226
427	675	187	527	675	227
428	700	188	528	700	228
429	725	189	529	725	229

IC-24G: DISPLAY/OPERATING FREQUENCY/BCD(N) CHART (continued)

DISPLAY	OPERATING FREQUENCY	BCD(N)	DISPLAY	OPERATING FREQUENCY	BCD(N)
430	144.750MHz	190	530	145.750MHz	230
431	775	191	531	775	231
432	800	192	532	800	232
433	825	193	533	825	233
434	850	194	534	850	234
435	875	195	535	875	235
436	900	196	536	900	236
437	925	197	537	925	237
438	950	198	538	950	238
439	975	199	539	975	239

Reference Oscillator

IC5 (TC5082P) consists of a crystal oscillator and a 12-stage high-speed divider. The crystal oscillator produces 10.24MHz (IC-24G: 6.4MHz) signals, and signals that have been divided down to 1/1024, i.e., 10KHz (IC-24G: 1/256, i.e., 25KHz) signals, are obtained at the 10th (IC-24G: 8th) stage of the divider.

Phase Comparator

IC4 (TC5081P) comprises a digital phase comparator. Divided signals from IC3 and 10KHz (IC-24G: 25KHz) reference signals from IC5 are fed to the phase comparator, which produces an output proportional to the phase difference of the two inputs. This output is passed through the low pass filter consisting of R29 ~ 31, C28 and C29, and is supplied to D6 of the VCO, to control the VCO frequency.

If the frequency of IC3 output is higher than the reference frequency set by IC5, voltage supplied to D6 falls and the VCO frequency is lowered. If IC3 output frequency is lower than the reference frequency, voltage to D6 becomes higher and the VCO frequency is increased. In this way, the VCO frequency is locked to the reference frequency.

Transmit Muting Circuit

When the PLL is locked, voltage at Pin No. 4 of IC4 becomes equal to the power supply voltage. But when the lock is released, pulses with a width proportional to the phase difference appear at this pin.

These pulses are integrated by R27, C26, and supplied to the base of Q2 (2SA1015). When Q2 base voltage exceeds the junction voltage, Q2 conducts, and voltage is supplied to the base of Q3 (2SC1815), and Q3 also conducts. Voltage at the collector of Q3 becomes zero, base voltage of Q32 in the main unit is lowered, power supply voltage for transmit becomes zero, and transmitting operations are stopped.

R4 and C27 make a time-delay to start transmitting of about 30 milliseconds. This prevents sweep of the transmitting signals in the duplex mode.

TONE CALL UNIT

This unit generates a 1750Hz tone burst for opening a repeater. When the TONE CALL Switch is depressed, the circuit is actuated.

IC1 (TC5082) comprises a crystal oscillator and dividers. IC1 oscillates 7.168MHz and its output signal is divided 1/4096, and a highly stable 1750Hz tone burst is obtained.

SECTION VIII TROUBLE SHOOTING

Your IC-22U/24E/24G has been tested very carefully at the factory before shipping. The chart below has been designed to help you correct any problems which are not equipment malfunctions. If you are not able to locate the problem and/or solve it through use of this chart, please contact your dealer or ICOM distributor for assistance.

Problem	Possible Cause	Solution
1. Power does not come ON when the switch is turned.	Power cord is improperly connected. Power cord is connected with the polarity reversed. Blown fuse.	Carefully reconnect power cord. Disconnect the power cord, replace the blown fuse, then reconnect the power cord observing proper polarity. Check for the cause, then replace the fuse with a new one.
2. No sound comes from the speaker.	VOLUME Control knob is completely counterclockwise, but not "clicked OFF". The unit is in the transmit mode, by the PTT switch on the microphone. SQUELCH setting is turned too far clockwise. External speaker is in use. The internal speaker cable is not connected.	Turn the knob clockwise to a suitable level. Put the unit in the receive mode. Turn the SQUELCH control counterclockwise until noise can be heard and reset it just below the threshold. Check if the external speaker plug is inserted properly or if the external speaker cable is cut. Connect the speaker connection.
3. Sensitivity is low and only strong signals are audible.	The antenna feed line is cut or shorted.	Check the feed line and correct any improper condition.
4. No or low RF output.	RF Power switch is set at the Low position. PTT switch is not functioning due to bad connection of the MIC connector. The antenna feeder is cut or shorted.	Set the RF Power switch to the High (normal) position. Check the connection of the MIC connector and correct any problems. Check the antenna feeder and correct any problems.
5. No modulation.	Bad connection of the MIC connector. The MIC cable is cut.	Check the connection of the MIC connector and correct any problems. Repair the disconnected or cut wire.

Problem	Possible Cause	Solution
<p>6. The receive mode functions properly and your signals are transmitted, but you are unable to make contact with another station. (When desiring SIMPLEX mode.)</p> <p>(When desiring DUPLEX mode.)</p>	<p>The OFFSET switch is in the +600 or -600 position.</p> <p>The SHIFT Switch is pushed and the frequency is offset from the communicating frequency.</p> <p>The OFFSET Switch is in the SIMP position.</p> <p>Improper input/output frequency of the repeater.</p>	<p>Set the OFFSET Switch to the SIMP position.</p> <p>Push the SHIFT Switch again and set to the out position.</p> <p>Set the OFFSET switch to the +600 or -600 position, and the DUPLEX MODE SELECT Switch to the DUP 1 or DUP 2 position according to repeater input/output frequency.</p>
<p>7. Rear side of the unit case become hot.</p>	<p>As rear side of the case is used as a heatsink for the transmitter final transistor even during normal operation, it may get as hot as 35°C (95°F) above room temperature.</p>	<p>Make sure that the area around the unit has as much ventilation as possible.</p>

SECTION IX VOLTAGE CHARTS

NOTE: Measuring instrument is a 50K Ω /V multimeter.

MAIN UNIT TRANSISTORS

TR No.	TRANSMIT				RECEIVE				REMARKS
	BASE OR GATE1	GATE2	COLLECTOR OR DRAIN	EMITTER OR SOURCE	BASE OR GATE1	GATE2	COLLECTOR OR DRAIN	EMITTER OR SOURCE	
Q 1	0		-8.0	0	8.0		7.0	7.8	
Q 2	0	0	0	0.1	0	4.2	8.6	0.7	
Q 3	0	0	0	0	0	0	9.0	0	
Q 4	0		0	0.1	0		7.8	0.7	
Q 5	0		0	0	2.0		9.6	1.7	
Q 6	0		0	GND	0.7		2.2	GND	
Q 7	0		0	0	4.6		6.6	4.2	
Q 8	0		0	0	1.4		4.5	1.1	SQL opened
					0		9.6	0	SQL closed
Q 9	0		0	0	2.8		9.6	2.4	
Q10	6.0		9.8	5.5	6.0		9.8	5.5	
Q11	0		8.0	0	6.5		7.8	6.4	SQL opened
					0		8.2	0	SQL closed
Q12	0.6		0	GND	0.3		8.8	GND	SQL opened
					0.6		0	GND	SQL closed
Q13	0		0	0	1.3		5.6	0.8	
Q14	0		0	0	1.3		9.4	0.7	
Q15	0		13.8	0.4	0		13.8	0.4	Po HIGH
	-0.5		13.8	0.3					Po LOW
Q16	13.0		13.8	13.8	13.0		13.8	13.8	Po HIGH
	13.0		3.0	13.8					Po LOW
Q17	-0.1		13.8	GND	0		13.8	GND	
Q18	0.6		13.8	GND	0		13.8	GND	
Q19	0.8		13.8	0.1	0		13.8	0.1	Po HIGH
	0.8		3.0	0.1					Po LOW
Q20	0.6		9.3	GND	0		0	GND	Po HIGH
	0.3		7.5	GND					Po LOW
Q21	8.8		1.1	9.6	0		0	0	Po HIGH
	9.4		0.5	9.6					Po LOW
Q22	0	4.4	8.4	1.1	0	0	0	0	
Q24	7.8		9.2	7.0	0		0	0	
Q25	5.6		9.4	5.0	5.6		9.4	5.0	
Q26	0.7		1.8	GND	0.7		1.8	GND	
Q27	0.6		0.7	GND	0.6		0.7	GND	
Q28	0.5		0.6	GND	0.5		0.6	GND	
Q31	10.0		12.0	9.5	10.0		12.0	9.5	
Q32	10.0		12.0	9.5	0.9		13.8	0	
Q33	0.7		10.0	0.3	1.5		0.9	0.8	
Q34	0.8		13.5	0	10.0		12.5	9.5	

MAIN UNIT IC

IC No.	TRANSMIT								RECEIVE								REMARKS
	PIN No.								PIN No.								
	1	2	3	4	5	6	7	8	1	2	3	4	5	6	7	8	
IC1	0	0	0	GND	0.3	0	0.3		5.0	2.0	2.0	GND	8.2	3.0	8.4		
IC2	1.5	13.8	13.0	8.0	0.5	13.8	0	5.0	1.5	13.8	13.0	8.0	6.5	13.8	0.2	1.9	
IC3	7.3	3.4	GND	3.0	6.3	9.5	9.5	9.5	0	0	GND	0	0	0	0	0	

PLL UNIT TRANSISTORS

TR No.	TRANSMIT				RECEIVE				REMARKS
	BASE OR GATE1	GATE2	COLLECTOR OR DRAIN	EMITTER OR SOURCE	BASE OR GATE1	GATE2	COLLECTOR OR DRAIN	EMITTER OR SOURCE	
Q1	1.6		9.2	0.9	1.6		9.2	0.9	
Q2	9.2		0	9.6	9.2		0	9.6	
Q3	0		10.0	GND	0.7		0.1	GND	
Q4	1.4		5.0	0.7	1.4		5.0	0.7	
Q5	0.6		7.4	GND	0.6		7.4	GND	
Q6	1.5		9.0	0.8	1.5		9.0	0.8	
Q7	1.4		9.1	0.7	1.4		9.1	0.7	IC-24G
Q8	GND		7.5	2.5	GND		7.5	2.5	
Q9	1.0		6.4	0.4	1.0		6.4	0.4	

PLL UNIT IC IN TRANSMIT MODE

IC No.	PIN No.																REMARKS
	1	2	3	4	5	6	7	8	9	10	11	12	13	14	15	16	
IC1	9.5	8.8	0	0	0	8.8	0	0	0	9.5	9.5	0	0	9.5			SIMP, 145.00
IC2	0	0	0	0	0	0	0	0	9.5	9.5	0	0	0	9.5			SIMP, 145.00
IC3	9.5	RF	*	*	*	*	*	*	*	*	*	*	*	GND	GND	GND	17:0.1,18:GND
IC4	0	9.5	3.0	9.5	9.5	0	0.1	4.4	GND								
IC5	2.5	3.5	3.7	0	8.5	0	4.4	4.4	GND								
IC6	0	9.0	8.0	4.6	3.0	GND	0	0	3.0	4.6	4.6	4.6	8.0	0			
IC7	1.5	1.5	GND	8.0	8.8												
IC8	9.4	0	9.4	0	0	0	0	8.8	9.4	0	0	9.4	9.4	9.4			IC-24G
IC9	0	1.4	GND	8.4	9.4	9.4	9.4	9.4	0	9.4	0	0	0	0			IC-24G

PLL UNIT IC IN RECEIVE MODE

IC No.	PIN No.																REMARKS
	1	2	3	4	5	6	7	8	9	10	11	12	13	14	15	16	
IC1	9.5	8.8	0	0	9.5	8.8	0	0	0	9.5	9.5	0	0	9.5			SIMP, 145.00
IC2	0	0	0	0	0	0	0	0	9.5	9.5	9.5	0	8.8	9.5			SIMP, 145.00
IC3	9.5	RF	*	*	*	*	*	*	*	*	*	*	*	GND	GND	GND	17:0.1,18:GND
IC4	0	9.5	3.0	9.5	9.5	0	0.1	4.4	GND								
IC5	2.5	3.5	3.7	0	8.5	0	4.4	4.4	GND								
IC6	0	9.0	8.0	4.6	3.0	GND	0	0	3.0	4.6	4.6	4.6	8.0	0			
IC7	1.5	1.5	GND	8.0	8.8												
IC8	9.4	0	9.4	0	0	0	0	8.8	9.4	0	0	9.4	9.4	9.4			IC-24G
IC9	0	1.4	GND	8.4	9.4	9.4	9.4	9.4	0	9.4	0	0	0	0			IC-24G

*: 9.0V or 0V depending on thumbwheel switches.

TONE CALL UNIT (IC-24E/24G only)

IC No.	PIN No.																REMARKS
	1	2	3	4	5	6	7	8	9	10	11	12	13	14	15	16	
IC1	1.4	2.6	3.2	3.4	6.8	-	-	-	GND								

Note: When the tone call switch is pressed.

SECTION X BLOCK DIAGRAM

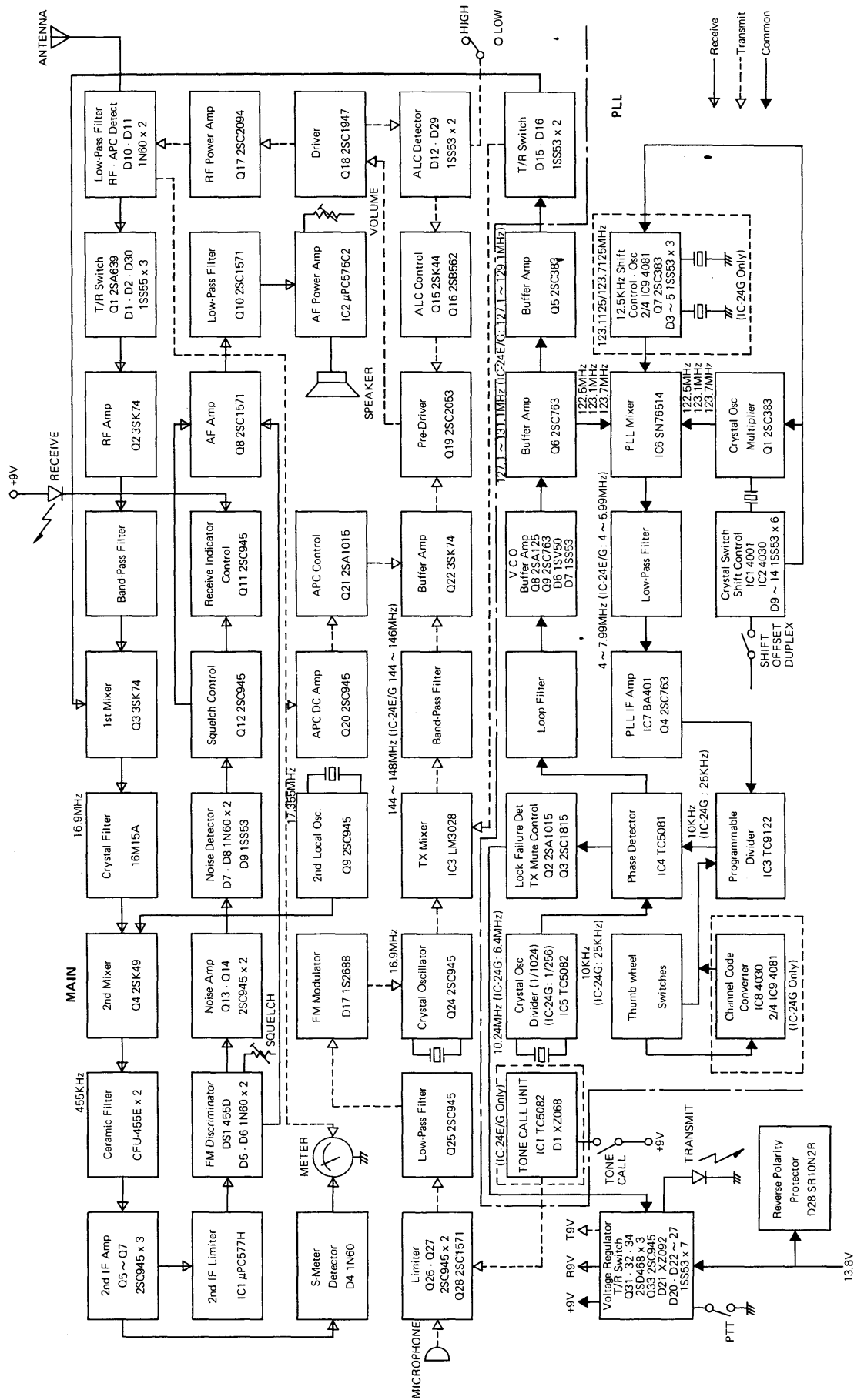



ICOM INCORPORATED

1-6-19, KAMI KURATSUKURI, HIRANO-KU,
OSAKA JAPAN