

MC-90

INSTRUCTIONS MANUAL

KENWOOD

KENWOOD CORPORATION

©PRINTED IN JAPAN B62-0267-08(MC)
02/12 11 10 9 8 7 6 5 4 3 2

Thank you for Purchasing this microphone. (MC-90)
The MC-90 is a high-grade microphone that contains a high-quality transducer element that was designed for use with high performance audio equipment. It gives unrivaled transmission sound quality when used with a transmitter equipped with DSP (digital signal processing)

IMPORTANT:

Please read this Instruction Manual carefully before using the product.

■ Ratings

Type	Dynamic microphone with PTT circuit
Microphone element	Moving-coil, unidirectional type.
Impedance	250Ω
Sensitivity (dB)	-78dB (0dB = 1V / μBAR, 1000Hz)
Dimensions (mm)	90 × 205 × 176
Weight (k g)	1.1k g

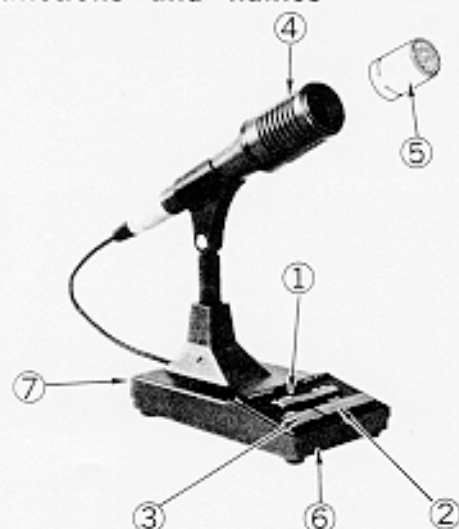
■ Functions and names**① UP/DWN (Up/down) key**

This key increments or decrements the transmit/receive frequency. If you hold the key down, the frequency changes continuously.

② PTT (Push-to-talk button)

Hold this button down to transmit.

③ LOCK switch

Press this switch to lock the unit in the transmit mode. Press it again to return to receive mode.

④⑤ Replacement microphone head

You can change the frequency response of the microphone by changing the microphone head. (Refer to the accompanying chart for the audio frequency response of each head).

⑥ Bottom switch

You can change the low-frequency range response by setting the switch to the M, V1, or V2 position. (Refer to the accompanying chart for the audio frequency response in each position).

⑦ Microphone pins**● Pin numbers and names**

Pin No.	Pin name
1	MIC
2	PTT, LOCK
3	UP
4	DOWN
5	NC
6	NC
7	MIC-GND
8	GND

● Connector pin layout as viewed from the front**Note:**

Since the MC-90 uses a transducer with a wide frequency response, it is some what less sensitive than conventional transmitter microphones. When you use the MC-90, adjust the MIC control for an on-Scale ALC reading.

■ Frequency Response Curve (Graph showing the output level versus the input audio frequency in the voice-frequency range centered around 1 kHz)

● When head ④ is used

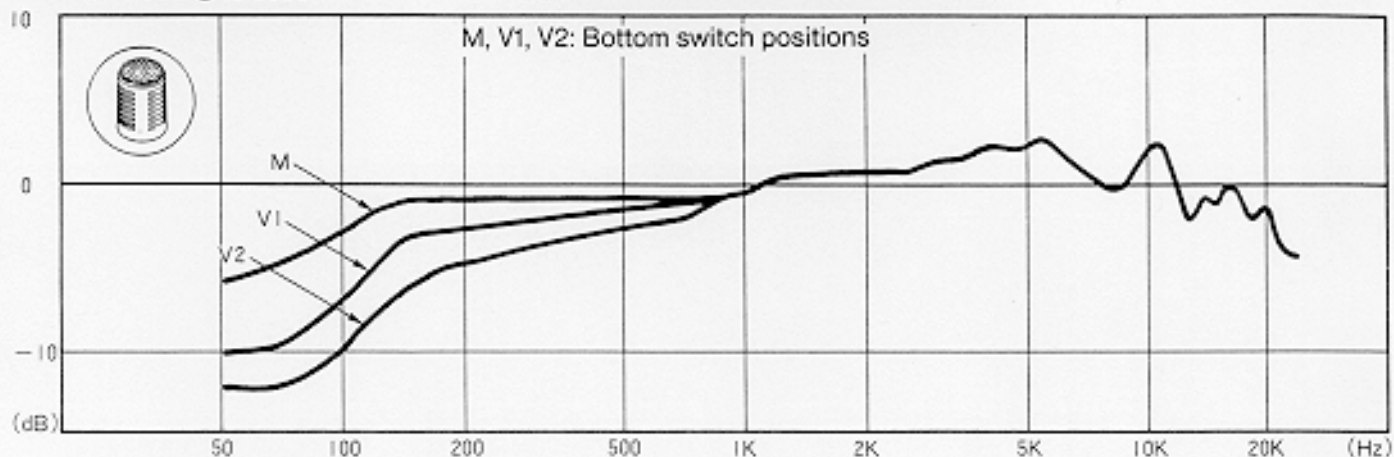

● When head ⑤ is used

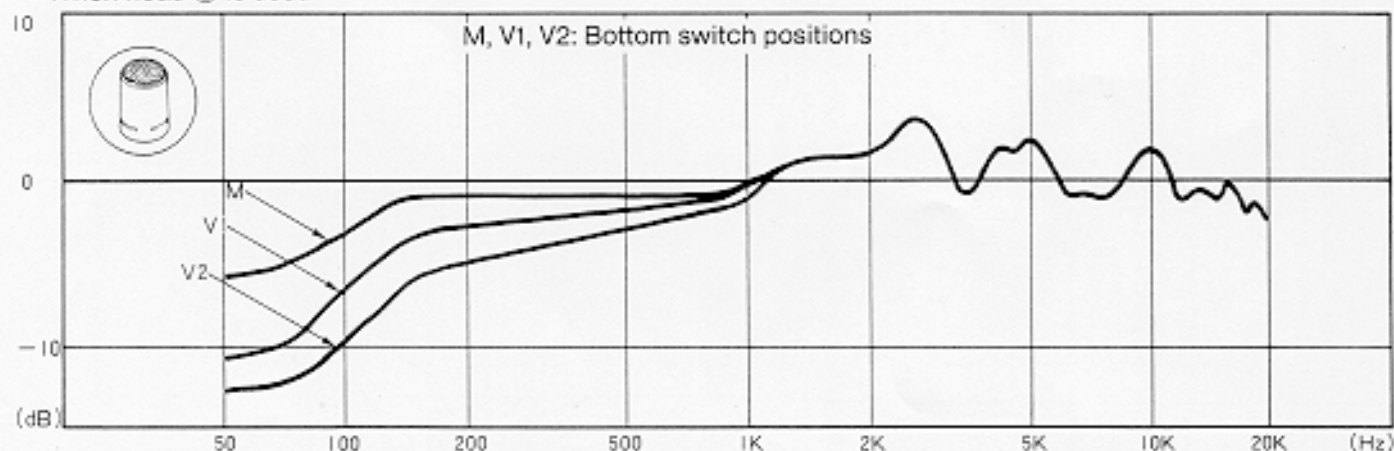

■ Circuit diagram

● Microphone stand connection diagram

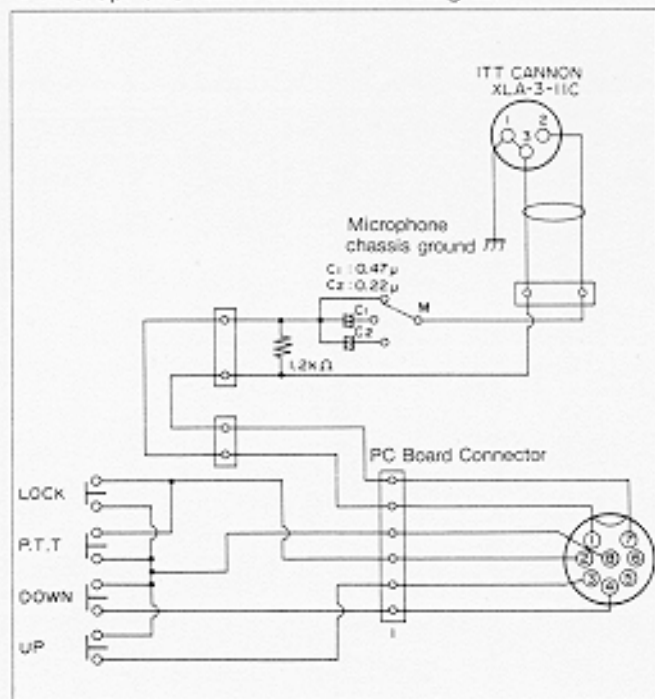

● Audio connection diagram

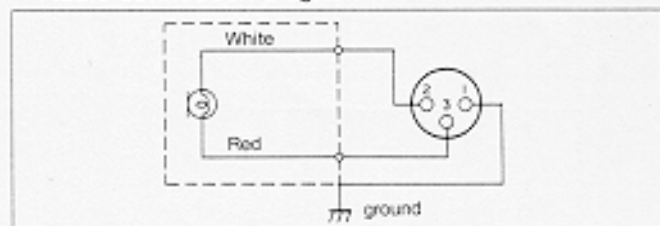

● Microphone cable connection diagram

