

YAESU

FT-1000MP

HF Transceiver

Technical Supplement



YAESU MUSEN CO., LTD.

1-20-2 Shimomaruko, Ota-Ku, Tokyo, 146, Japan

YAESU U.S.A.

17210 Edwards Rd., Cerritos, CA 90703, U.S.A.

YAESU INTERNATIONAL SALES, (Caribbean, Central & So. America)
7270 NW 12th St., Suite 320, Miami, FL 33126, U.S.A.

YAESU EUROPE B.V.

Snipweg 3, 1118DN Schiphol, The Netherlands

YAESU UK LTD.

Unit 2, Maple Grove Business Centre,
Lawrence Rd., Hounslow, Middlesex, TW4 6DR, U.K.

YAESU GERMANY GmbH

Am Kronberger Hang 2, D-65824 Schwalbach, Germany

YAESU HK LTD.

11th Floor Tsim Sha Tsui Centre, 66 Mody Rd.,
Tsim Sha Tsui East, Kowloon, Hong Kong

Contents

<i>Introduction</i>	1-1
<i>Specifications</i>	1-2
<i>Chip Componenets & Replacement</i>	1-3
<i>Transceiver Disassembly & PCB Unit Access</i>	2-1
<i>Battery/Fuse Replacement & CPU Resetting</i>	2-4
<i>Alignment</i>	3-1
<i>Circuit Description</i>	4-1
<i>Block & Interconnection Diagram</i>	5-1
<i>PCB Diagrams & Parts Lists</i>	
RF Unit	6A-1
IF Unit	6B-1
AF Unit	6C-1
DDS-CAR Unit	6D-1
I-DET Unit	6E-1
Local Unit	6F-1
DDS-PLL Unit	6G-1
DDS-SUB Unit	6H-1
REF Unit	6I-1
CNTL Unit	6J-1
Display Unit	6K-1
LPF Unit	6L-1
100W-PA Unit	6M-1
Tuner-Main Unit	6N-1
Tuner-CNTL Unit	6O-1
ALC Unit	6P-1
DSP-A Unit	6Q-1
DSP-D Unit	6R-1
RX2 Unit	6S-1
RX2 PLL-DDS Unit	6T-1
RX2 CAR-DDS Unit	6U-1
ANT Unit	6V-1
REG Unit	6W-1
SW-A, -B, -C, -D Unit	6X-1
VR-A, -B, -C, D, E, -F Unit	6Y-1
ENC-A, MIC, HP Unit	6Z-1
KEY Unit	6a-1
LED Unit	6b-1
PS Unit	6c-1
SSB-Filter Unit	6d-1
INV Unit	6e-1
HPF Unit	6f-1
Mechanical Details (Exploded Views & Mechanical Parts)	7-1
Hand Microphone MH31-B8	8A-1

Cut out the label at the right, and place it behind the clear plastic window in the spine of the manual.

FT-1000MP
Technical Supplement

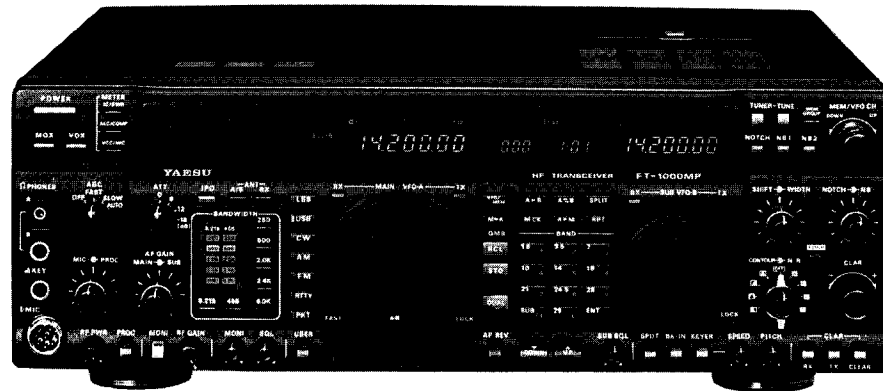

This manual provides technical information necessary for servicing the Yaesu FT-1000MP HF transceiver. It does not include information on installation and operation, which are described in the FT-1000MP Operating Manual, provided with each transceiver, or on FT-1000MP accessories, which are described in manuals provided with each.

The FT-1000MP is carefully designed to allow the knowledgeable operator to make nearly all adjustments required for various station conditions, modes and operator preferences simply from the controls on the panels, without opening the case of the transceiver. The FT-1000MP Operating Manual describes these adjustments, plus certain internal settings.

Servicing this equipment requires expertise in handling surface mount chip components. Attempts by non-qualified persons to service this equipment

may result in permanent damage not covered by warranty. For the major circuit boards, each side of the board is identified by the type of the majority of components installed on that side. In most cases one side has only chip components, and the other has either a mixture of both chip and lead components (trimmers, coils, electrolytic capacitors, packaged ICs, etc.), or lead components only.

While we believe the technical information in this manual is correct, Yaesu assumes no liability for damage that may occur as a result of typographical or other errors that may be present. Your cooperation in pointing out any inconsistencies in the technical information would be appreciated. Yaesu Musen reserves the right to make changes in this transceiver and the alignment procedures, in the interest of technological improvement, without notification of the owners.

Specification

General

Rx frequency range: 100 kHz — 30 MHz
 Tx frequency ranges: 160 -10m amateur bands only
 Freq. Stability: ± 10 ppm (-10 ~ +50°C)
 ± 2.0 ppm (0° ~ +50°C) w/TCXO-4
 ± 0.5 ppm (0° ~ +50°C) w/TCXO-6
 Freq. Accuracy: ± 7 ppm (except FM, ± 500 Hz)
 w/TCXO-4: ± 2 ppm (FM ± 460 Hz)
 w/TCXO-6 ± 0.5 ppm (FM ± 500 Hz)
 Operating temperature Range: (-10 ~ +50°C)
 Emission modes: LSB, USB, CW, FSK, AM, FM
 Frequency steps: 0.625/1.25/2.5/5/10 Hz for SSB,
 CW, RTTY & Packet; 100 Hz for AM and FM
 Antenna impedance: 50Ω unbalanced
 Power Consumption:

Input	Rx (no signal)	Rx (signal)	Tx (100W)
100~125 VAC	70 VA	80 VA	550 VA
200~240 VAC	80 VA	90 VA	600 VA
13.8 VDC	2.4 A	2.8 A	19 A

Supply voltage: 100~125, 200~234 VAC, 50/60 Hz
 Dimensions (WHD): 410 × 135 × 347 mm
 Weight (approx.): 15 kg. (33 lbs)

Transmitter

Power output: adjustable up to 100 watts
 (25 watts AM carrier)
 Duty cycle: 100% @ 50 watts, 50% @ 100 watts
 (FM & RTTY, 3-minute Tx)
 Modulation types:
 SSB: J3E Balanced, filtered carrier
 AM: A3E Low-level (early stage)
 FM: F3E Variable reactance
 AFSK: J1D, J2D Audio frequency shift keying
 Maximum FM deviation: ± 2.5 kHz
 FSK shift frequencies: 170, 425 and 850 Hz
 Packet shift frequencies: 200, 1000 Hz
 Harmonic radiation: at least 50 dB below peak output

SSB carrier suppression: at least 40 dB below peak output
 Undesired sideband suppression: at least 50 dB below peak output
 Audio response (SSB): not more than -6 dB from 400 to 2600 Hz
 3rd-order IMD: -31 dB @ 100 watts PEP, or better
 Microphone impedance: 500 to 600 Ω

Receiver

Circuit type: quad-conversion superheterodyne
 (triple conversion for FM)
 Intermediate frequencies: **Main Rx** **Sub Rx**
 70.455 MHz 47.21 MHz
 8.215 MHz 455 kHz
 455 kHz

(with preamp on, for 10 dB S/N, 0 dBμ - 1 μV)				
Frequency → Mode (BW) ↓	150 – 250 kHz	250 – 500 kHz	0.5 – 1.8 MHz	1.8 – 30 MHz
SSB, CW (2.4 kHz)	5 μV	4 μV	2 μV	0.25 μV
AM (6 kHz)	40 μV	32 μV	16 μV	2 μV
29-MHz FM (12 dB SINAD)	—	—	—	0.5 μV

Sensitivity:
 Selectivity (-6/-60 dB):
 Dynamic Range: 108 dB (@50 kHz, 500-Hz BW, IPO on)
 Squelch sensitivity:
 1.8 ~ 30 MHz (CW, SSB, AM): <math>< 2.0</math> μV
 28 ~ 30 MHz (FM): <math>< 0.32</math> μV
 IF rejection (1.8 ~ 30 MHz): 80 dB or better (Main Rx)
 60 dB or better (Sub Rx)
 Image rejection (1.8 ~ 30 MHz): 80 dB or better (Main)
 50 dB or better (Sub)
 IF shift range: ± 1.12 kHz
 Max. audio output: 1.5 W into 4Ω with <math>< 10\%</math> THD
 Audio output impedance: 4 to 8 Ω

Specifications are subject to change, in the interest of technical improvement, without notice or obligation.

Chip Component Information

Chip Component Information

The diagrams below indicate some of the distinguishing features of common chip components.

Capacitors

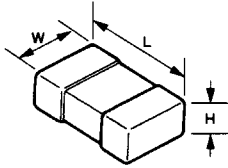

(Unit: mm)

Type	L	W	H
2125	2.0	1.25	0.35~0.50
1608	1.6	0.8	0.65~0.95
1005	1.0	0.5	0.45~0.55

Tantalum Capacitors

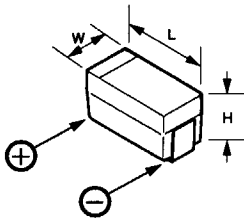

(Unit: mm)

Type	L	W	H
P	2.0	1.25	1.2
A	3.2	1.6	1.6
B	3.4	2.8	1.9
C	5.8	3.2	2.3

Resistors

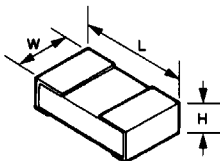

Type RMC 1/10W, 1/16W

Marking* 100, 222, 473 ...

Indicated Letters

1 2 3 4
5 6 7 :
9 0 .

(Unit: mm)

Type	L	W	H
1/10	2.0	1.25	0.5
1/16	1.6	0.8	0.45
1/16S	1.0	0.5	0.35

473

Ten unit	One unit	Multiplier code
0	0	10 ⁰
1	1	10 ¹
2	2	10 ²
3	3	10 ³
4	4	10 ⁴
5	5	10 ⁵
6	6	10 ⁶
7	7	10 ⁷
8	8	10 ⁸
9	9	10 ⁹

Examples:

100 = 10Ω
 222 = 2.2kΩ
 473 = 47kΩ

Chip Component Information

Replacing Chip Components

Chip components are installed at the factory by a series of robots. The first one places a small spot of adhesive resin at the location where each part is to be installed, and later robots handle and place parts using vacuum suction.

For single sided boards, solder paste is applied and the board is then baked to harden the resin and flow the solder. For double sided boards, no solder paste is applied, but the board is baked (or exposed to ultra-violet light) to cure the resin before dip soldering.

In our laboratories and service shops, small quantities of chip components are mounted manually by applying a spot of resin, placing with tweezers, and then soldering by very small dual streams of hot air (without physical contact during soldering). We remove parts by first removing solder using a vacuum suction iron, which applies a light steady vacuum at the iron tip, and then breaking the adhesive with tweezers.

The special vacuum/desoldering equipment is recommended if you expect to do a lot of chip replacements. Otherwise, it is usually possible to remove and replace chip components with only a tapered, temperature-controlled soldering iron, a set of tweezers and braided copper solder wick. Soldering iron temperature should be below 280° C (536° F).

Precautions for Chip Replacement

- Do not disconnect a chip forcefully, or the foil pattern may peel off the board.
- Never re-use a chip component. Dispose of all removed chip components immediately to avoid mixing with new parts.
- Limit soldering time to 3 seconds or less to avoid damaging the component and board.

Removing Chip Components

- Remove the solder at each joint, one joint at a time, using solder wick whetted with non-acidic fluxes as shown below. Avoid applying pressure, and do not attempt to remove tinning from the chip's electrode.

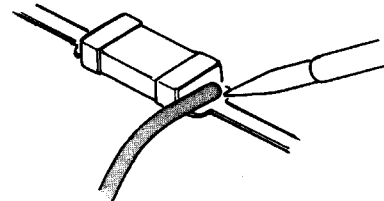

- Grasp the chip on both sides with tweezers, and gently twist the tweezers back and forth (to break the adhesive bond) while alternately heating each electrode. Be careful to avoid peeling the foil traces from the board. Dispose of the chip when removed.

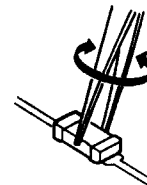

- After removing the chip, use the copper braid and soldering iron to wick away any excess solder and smooth the land for installation of the replacement part.

Installing a Replacement Chip

As the value of some chip components is not indicated on the body of the chip, be careful to get the right part for replacement.

- Apply a small amount of solder to the land on one side where the chip is to be installed. Avoid too much solder, which may cause bridging (shorting to other parts).

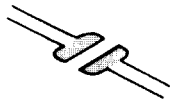

- Hold the chip with tweezers in the desired position, and apply the soldering iron with a motion line as indicated by the arrow in the diagram below. Do not apply heat for more than 3 seconds.

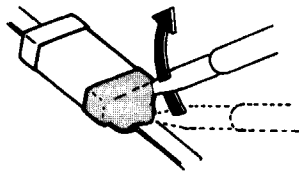

- Remove the tweezers and solder the electrode on the other side in the manner just described.

Chip Component Information

Notes:

As the value of some chip components is not indicated on the body of the chip, be careful to get the right part for replacement.

Apply a small amount of solder to the land on one side where the chip is to be installed. Avoid too much solder, which may cause bridging (shorting to other parts).



Hold the chip with tweezers in the desired position, and apply the soldering iron with a motion line as indicated by the arrow in the diagram below. Do not apply heat for more than 3 seconds.



Remove the tweezers and solder the electrode on the other side in the manner just described.

Transceiver Disassembly & PCB Unit Access

Disassembly Tips

The FT-1000MP uses over 35 individual unit/assemblies, interconnected for maximum performance and compactness. With the exception of routine installations (filters, options, backup battery replacement, etc.), we do not recommend further disassembly. Circuit repair and alignment require familiarity with complex analog and digital circuitry, and access to the specialized test equipment needed for circuit analysis. Therefore, we recommend repairs be conducted by at an authorized repair facility via the Yaesu dealer where the unit was purchased.

When proceeding with transceiver disassembly, keep the following items in mind -

- Various types of screws sizes and thread pitch are used - separate screws and keep them with the unit they were removed from.
- When unplugging wiring connectors or mini coax cables, make note of any color coding to facilitate easy identification during reassembly.

Top Cover Removal

Turn the transceiver off, and disconnect all cables. Remove the 9 screws affixing the top cover, then tilt and pull the cover off. This exposes the ALC and ANT Units.

⚠ Warning! - high voltages present inside!

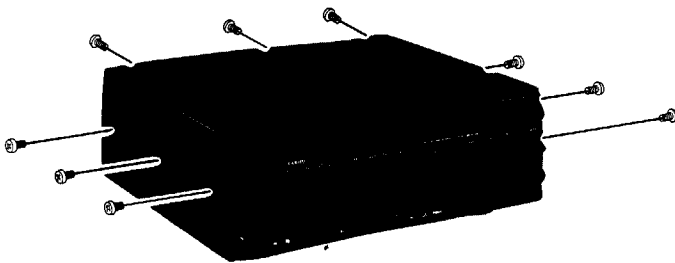

ALC & ANT Unit

- Remove the 4 screws from the plate (cradle) mounting the ALC and ANT Units, being careful not to lose the two copper grounding strips on the rear pair of screws. Also note how the tin grounding strap from the RX2 Unit is affixed.

- Tilt the mounting plate up slightly, then slide it forward and upward to loosen the assembly. Flip the unit over to expose the TUNER Unit underneath
- To remove the ANT Unit, desolder the leads from the two SO-239 jacks and ground lead. Remove the green-banded coax from J8702, the plug from J8701, and the two mounting screws from the PCB to free the ANT Unit.
- To remove the ALC Unit, remove the plugs from jacks J6801, 6802, 6803, 6804, 6805, 6806, 6807, 6808, 6809, 6810, and 6811, being careful to note lead color coding. Remove the 3 mounting screws from the PCB to free the ALC Unit.

TUNER Unit

- Flip the mounting plate over to expose the TUNER Unit, then remove the red and green banded coax cables from their respective connectors.
- Remove the three plugs from jacks J6504, 6505, and 6506. Next remove the 3 mounting screws affixing the TUNER Unit to the mounting plate

Loudspeaker Unit

- Remove the 4 rubber-grommeted screws from the loudspeaker frame-mount to loosen the assembly.
- Next remove the red and black leads to free the speaker and mount, exposing the EDSP Unit. To remove the speaker from its mount, remove the remaining 4 screws

LOCAL Unit

- Remove 1 rear-panel screw and the 6 remaining screws from the steel plate to expose the LOCAL Unit.
- To remove the LOCAL Unit, remove the amber, green and blue-banded coax cables, the plugs from J4005, 4006, 4007, 4008, 4009, and the ribbon cable from J4004. Next remove its 5 mounting screws and lift the unit free.

EDSP Unit

- Remove the two screws from the mounting tabs to loosen the EDSP Unit.
- Remove the red and blue banded plug from J7001, then remove the 4 screws affixing the shield cover and remove the cover to expose the DSP-A Unit.

Transceiver Disassembly & PCB Unit Access

- Remove the 3 mounting screws to loosen the DSP-A PCB, then remove the flat ribbon cable from J7003 to remove the DSP-A Unit.
- Remove the 4 screws from the remaining cover to expose the DSP-B Unit. Next remove the plugs from J7101 and 7102, and the remaining 2 screws to remove the DSP-B Unit PCB.

DC Fan

- Remove the 2 screws from the fan mounting bracket to loosen the unit.

PA/LPF Assembly

- Remove the remaining 4 screws from the aluminum PA Unit heatsink (the other 2 screws were removed in the previous step), and lift the unit slightly to loosen it.
- On the underside of the unit, remove the single screw affixing the cover plate, and remove the plate to expose the PA and LPF Units.
- Remove the amber, green, and red color-coded coax cables from J6002, 6003, and 6005, and the regular coax cable from J6001 on the LPF Unit.
- On the PA Unit, remove the plug from J6203, the amber color-coded coax cable from J6201, and the red & black DC leads from J6204 & 6205.
- To remove the LPF Unit with its frame assembly from the aluminum heatsink, remove the 4 screws from the from, and lift the unit free.
- To remove the LPF Unit from the frame, remove the four mounting screws and free the unit.
- To remove the PA Unit from the aluminum heatsink, remove the four mounting screws from drive and PA transistors Q6001, 6205, 6202 and 6203. Next, remove the 4 mounting screws from the PCB to free the Unit.
- Take care not to lose the mica insulator sheet for Q6001, and do not remove the paper insulator cutout affixed to the heatsink surface.

RF Unit

- Remove the 4 screws from the steel mounting plate from which the LPF-PA heatsink assembly was previously removed to expose the RF and REG Units.
- To remove the RF unit, first remove the coax cables from J1003, 1004, 1006, 1007, 1011, and 1013. Desolder the solder bead attaching the copper grounding sheet to the REG Unit.
- Next, remove the plug from J1010, and the flat ribbon cable from J1012. Now remove the 2 rear-

panel screws from the **BAND DATA** jack, then the 5 screws from the RF Unit PCB.

- Slide the RF Unit forward so that the rear panel connectors clear the rear panel, then

REG Unit

- To remove the REG Unit, first remove the 9 plugs from J9003, 9004, 9009, 9010, 9011, 9013, 9014, 9015, and 9017 (the fan unit can now be freed at this time). Next remove the 6 wiring leads from each screw terminal, carefully noting lead colors.
- Remove the single screw from the chassis side, then the 4 screws from the REG Unit PCB to free the unit (be careful not to remove the 3 screws attaching the REG Unit PCB to the regulator heatsink).

Bottom Cover Removal

- With the top cover off, remove the 7 screws affixing the bottom cover, then tilt and pull the cover off. This exposes the IF, AF, and CNTL Units on the bottom chassis, and the RX2 and REF Units on the left chassis side.

Warning! - high voltages present inside!

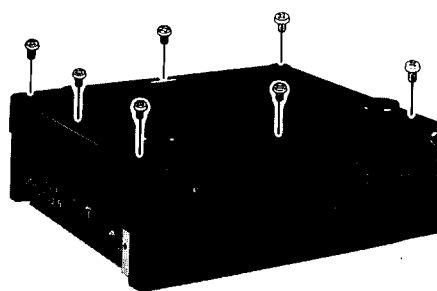

REF Unit (left side chassis)

- To remove the REF Unit, remove the 4 mounting screws from the PCB and free the unit.

RX2 Unit (left side chassis)

- To remove the RX2 Unit, first remove the flat ribbon cable from J8003, then the plug from J8001.
- Remove the 6 mounting screws from the PCB, slide the PCB forward slightly and lift it free.

Transceiver Disassembly & PCB Unit Access

CNTL Unit (chassis bottom)

- To remove the CNTL Unit, first remove the flat ribbon cables from J5003, 5004, 5008, 5009, 5010, 5014, 5015, 5016, 5017, 5018, 5019, 5026, 5030, and 5032.
- Next remove the plugs from J5001, 5002, 5011, 5013, 5020, 5021, 5022, and 5031.
- Remove the 6 mounting screws from the PCB, and the 2 screws affixing the rear panel DB-9 (CAT) jack.
- Slide the PCB forward slightly and lift it free.

AF Unit (chassis bottom)

- To remove the AF Unit, first remove the flat ribbon cables from J3006, 3015, 3024, 3028, and 3029.
- Next remove the plugs from J3003, 3004, 3005, 3007, 3012, 3013, 3017, 3018, 3022, 3026, 3031, 3032, 3033, 3035, 3037.
- Remove the 6 rear-panel screws affixing the DVS-3, PACKET, and RTTY jacks, then the 6 mounting screws affixing the AF Unit PCB.
- Slide the PCB forward slightly, tilt, and lift the unit free.

IF Unit

- To remove the IF Unit, first remove the flat ribbon cables from J2004, 2013, and 2014.
- Next, remove the plugs from J2002, 2009, 2011, and 2012. Then, remove the blue, amber, and yellow color-coded coax cables from J2007, 2003, and 2005, respectively. Also remove the coax cable from J2008.
- Remove the 6 mounting screws from the PCB to free the unit.

Front Panel Disassembly

- Remove the 2 large screws from the center of each side panel, and the 2 screws from the panel top. Also loosen the 2 screws at the bottom of each side panel.
- Slide the front panel assembly forward slightly, then fold it open and down. Take care to unravel the twisted white cable from its nylon tie down to permit folding the front panel fully.

AC Switched-Mode Power Supply

- To remove the power supply, first remove the two nylon plugs from their connectors on the power supply case, and front chassis cutout (for the front connector, first remove the plug, then use a small

 **Warning!** - high voltages present inside!

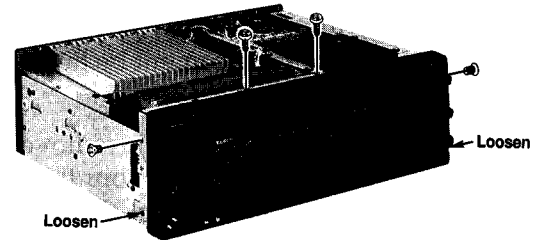

flat screwdriver to press the locking tabs in to remove the jack).

- Remove the 2 mounting screws from the main chassis, and the 2 from the chassis front to free the unit.

Display Unit

- To remove the display unit, first remove the plugs from jacks J5501, 5505, 5506, 5507, 5508, 5509, 5516, 5519, 5520, 5521, 5522, 5523, 5524, 5525, 5526, 5527, 5528, and 5529.
- Disconnect the flat ribbon cables from J5502, 5503, 5504, 5510, 5511, and 5518.
- Remove the 6 mounting screws from the PCB, and pull off the **AGC** and **ATT** knobs from the front panel.
- Slide the PCB forward, tilt and lift it free. This now exposes the KEY Unit, VR A, B, C, D, E, and F Units, SW Units A, B, C, and D, MIC and HP Units.

INV Unit

- First remove the 3 screws affixing the shield cover to expose the INV Unit.
- Unplug the Display Unit power cord from jack CN3 to free the Display Unit, then remove the 2 mounting screws from the PCB to free the INV unit.

This completes overall transceiver disassembly, and further disassembly is not recommended.

Battery/Fuse Replacement & CPU Resetting

Lithium Battery Replacement

A 3-V Type CR2032 Lithium Battery (BT5001) is located on the CNTL UNIT board (underside) of the transceiver. This maintains the memorized data in your radio. Battery life is normally greater than five years, however, should replacement be needed, perform the following steps:

- With the top and bottom covers removed, note the location of the battery. Using your finger, slide the battery inward (you will feel slight pressure by the mounting spring), then slightly pry it up and outward so that it ejects freely through the slots in the battery holder.
- Carefully note battery polarity with the positive (+) side facing upward, and battery-type information. Install the replacement battery in the reverse manner.

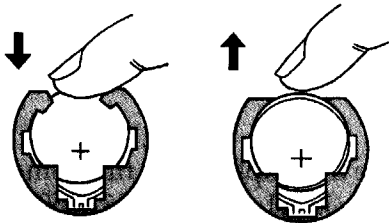

Memory Back-Up Switch

The rear panel memory **BACK UP** switch is normally kept in the ON position to ensure your memorized data is maintained (by a small amount of power from the lithium battery) when the radio is off, or the DC power source is removed.

- If you do not plan to operate your radio for extended periods of time, slide this switch to the OFF position to conserve battery life.
- Ensure the radio is on when sliding the switch back to the ON position, as this reduces the initial current demand on the battery by the radio's circuits from an un-powered state.
- Note: Memorized settings are lost and the radio returns to factory default settings when turning off the backup battery.

Internal 13.5V Fuse Replacement

The rear panel **13.5V** jack provides regulated, *separately fused* 13.5 VDC at up to 200 mA, to power external low-current devices. If your device requires more current, use a separate power source. In the event the internal fuse blows, it can be replaced. However, this requires moderate transceiver disassembly.

- With the top cover removed, locate the two screws mounting the fan assembly to the PA Unit heat sink. Remove the screws and move the fan assembly to one side.
- Remove the remaining four heat sink screws and lift the PA assembly from the chassis. You will need to unplug the mini coax (with the yellow band) from the RX ANT IN connector on the BPF UNIT.
- Remove the four screws from the PA Unit mount, and remove the mount to expose the BPF UNIT, and fuse labeled FH1001 (below).

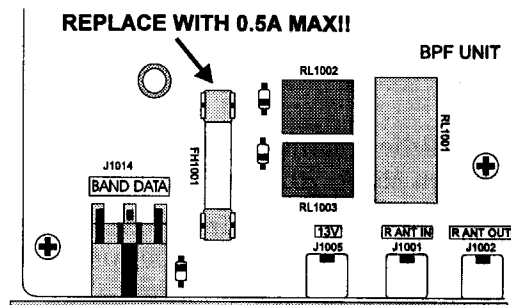

- Using a pair of fuse pullers, remove the blown fuse and replace only with a similar fast-blow type fuse (0.5A maximum).

Reassemble the PA UNIT mount, yellow-banded coax cable, PA UNIT, and fan assembly in reverse order, then replace the top cover.

CPU Keypad Reset

You can return *all transceiver settings* (menu selections) to their default values at any time by performing a CPU reset. Simply hold the **SUB** key, **0** & **ENT** keys together while turning the transceiver on.

Introduction and Precautions

The following procedures cover adjustments that are not normally required once the transceiver has left the factory. However, if damage occurs and some parts subsequently be replaced, realignment may be required. If a sudden problem occurs during normal operation, it is likely due to component failure; realignment should not be done until after the faulty component has been replaced.

We recommend that servicing be performed by authorized Yaesu service technicians, experienced with the circuitry and fully equipped for repair and alignment. If a fault is suspected, contact the selling dealer for instructions regarding repair. Authorized Yaesu service technicians have the latest modification information, and realign all circuits and make complete performance checks to ensure compliance with factory specifications after repairs.

Those who do undertake any of the following alignments are cautioned to proceed at their own risk. Problems caused by unauthorized attempts at realignment are not covered by the warranty policy. Also, Yaesu must reserve the right to change circuits and alignment procedures in the interest of improved performance, without notifying owners. Under no circumstances should any alignment be attempted unless the normal function and operation of the transceiver are clearly understood, the cause of the malfunction has been clearly pinpointed and any faulty components replaced, and the need for realignment determined to be absolutely necessary.

The following test equipment (and thorough familiarity with its correct use) is necessary for complete realignment. Correction of problems caused by misalignment resulting most step do not require all of the equipment listed, the interactions of some adjustments may require that more complex adjustments be performed afterwards. Do not attempt to perform only a single step unless it is clearly isolated electrically from all other steps. Rather, have all test equipment ready before beginning, and follow all of the steps in a section in the order they are presented.

Required Test Equipment

- Digital DC Voltmeter (high-Z, 1M Ω /V)
- RF Millivoltmeter

- AC Voltmeter
- RF Standard Signal Generator w/ calibrated output and dB scale, 0 dB μ =0.5 μ V
- AF Signal Generator with calibrated output
- Spectrum Analyzer or receiver (30 MHz)
- Frequency Counter
- 50- Ω Dummy Load (150~250 watts)
- 16.6- Ω Dummy load (150 watts)
- In-Line Wattmeter (150~250 watts, 50- Ω)
- Linear Detector
- RF Attenuator (150 watts, 40 dB) or coupler

Alignment Preparation & Precautions

A 50- Ω dummy load and in-line wattmeter must be connected to the antenna jack in all procedures that call for transmission, except where specified otherwise. Correct alignment is not possible with an antenna. Except where specified otherwise, the transceiver should be tuned to 14.2000 MHz, USB mode, and these controls set as indicated:

- **MOX, VOX, AGC, PROC, IPO, ATT** OFF
- **MIC & RF PWR** fully CCW (minimum)
- **AF** as required
- **SQL** fully CCW (minimum)
- **NOTCH & SHIFT** to 12-o'clock

Read each step to determine if the same test equipment will be required. If not, remove the test equipment (except dummy load and wattmeter, if connected) before proceeding. Correct alignment requires that the ambient temperature be the same as that of the transceiver and test equipment, and that this temperature be held constant between 20~30°C (68~86°F). If the transceiver is brought into the shop from hot or cold air it should be allowed time for thermal equalization with the environment before alignment. Alignments must only be made with oscillator shields and circuit boards firmly affixed in place. Also, the test equipment must be thoroughly warmed up before beginning.

Note: Signal levels in dB referred to in alignment are based on 0 dB μ =0.5 μ V.

Table Note: DC voltages should be within $\pm 10\%$ of those listed in the voltage tables.

Alignment

REF Unit

Carrier Frequency

Refer to the photograph below for REF Unit component locations and alignment points.

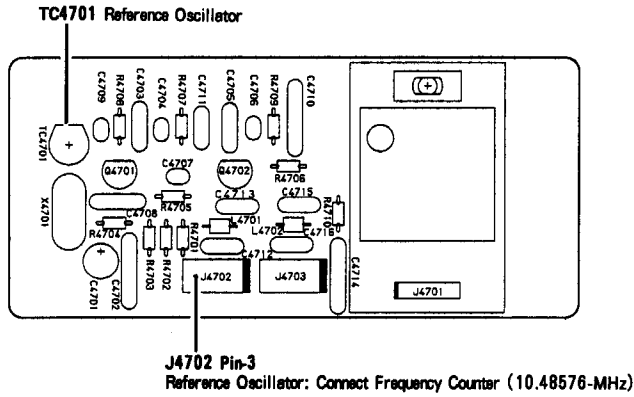

RX2 UNIT Test & Alignment Points

- Connect the frequency counter to J4702 Pin 3 of the REF Unit. If the counter frequency differs by more than 5 Hz from 10.485760 MHz, adjust TC4701 as necessary.

RX2 Unit

Local Section 2nd OSC

Refer to the photograph at the page bottom for RX2 Unit component locations and alignment points.

- Connect the RF millivoltmeter to TP8004, then adjust T8018, T8016, T8017 in succession several times for peak RF millivoltmeter indication.

2nd Local Frequency

- Connect the frequency counter to TP8004, then adjust T8018 for 46.775 MHz \pm 600 Hz on the frequency counter.

2nd Local Amplifier

- Connect the RF millivoltmeter to TP8004, then adjust T8017, T8016 in succession several times for peak RF millivoltmeter indication (at least 500 mVrms).

PLL BPF

- Connect the RF millivoltmeter to TP8003, then adjust T8012, T8013, T8004 in succession several times for peak RF millivoltmeter indication (at least 60 mVrms).

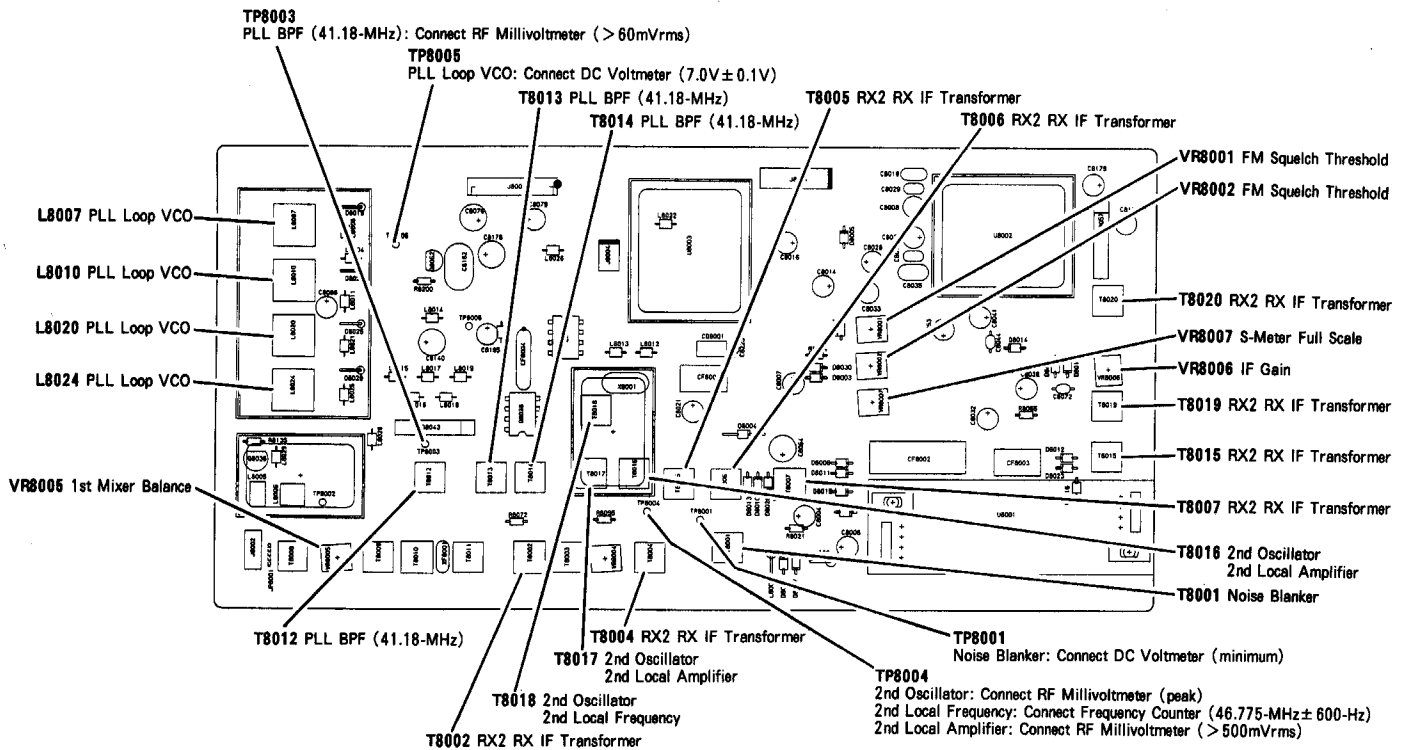

RX2 UNIT Test & Alignment Points

PLL Loop VCO

- Connect the DC voltmeter to TP8005. Tune the transceiver display to the frequencies shown in the chart below, and adjust the components listed for the corresponding voltage, or else confirm required voltages.

PLL Loop VCO Alignment		
Tune to:	Adjust/Confirm	for
7.499 MHz	adjust L8007	$7.0 \pm 0.1V$
7.500 MHz	confirm	$1.8 \pm 0.5V$
14.499 MHz	adjust L8010	$7.0 \pm 0.1V$
14.500 MHz	confirm	$1.8 \pm 0.5V$
21.999 MHz	adjust L8020	$7.0 \pm 0.1V$
22.000 MHz	confirm	$2.0 \pm 0.5V$
30.000 MHz	adjust L8024	$7.0 \pm 0.1V$
0.100 MHz	confirm	$1.8 \pm 0.5V$

RX Section Interstage Transformers

- Connect the RF signal generator to the antenna jack, then select the transceiver to FM mode. Inject a RF signal modulated with ± 1.75 kHz deviation of a 1 kHz tone.
- Preset T8003 to within 3 turns from top of the coil case, then select SSB mode.
- Inject a RF signal (no modulation), and adjust T8002, T8004~T8007, T8015, T8019 and T8020 in succession several times for peak S-meter indication

(adjust the injection level as necessary to keep the meter around low scale).

IF Gain

- Inject a +8 dB μ signal to the antenna jack, and tune for peak on the S-meter. Adjust VR8006 for 1-dot S-meter deflection.

S-Meter Full Scale

- Inject +100 dB μ to the antenna jack, and tune for peak on the S-meter. Adjust VR8007 for S9 +60 dB on the S-meter.

1st Mixer Balance

- Set the VR8005 for 12-o'clock position.

FM squelch threshold

- In FM mode, with no signal at the antenna jack, set the **SQL** control 11-o'clock position. Adjust VR8001 so that the squelch just closes.

SSB Squelch Threshold

- In the SSB mode, with no signal at the antenna jack, set the **SQL** control 10-o'clock position. Adjust VR8002 so that the squelch just closes.

Noise Blanker

- Connect the DC voltmeter to TP8001, select **NB1** or **NB2**, then inject a +40 dBu signal to the antenna jack.
- Adjust T8001 for minimum indication in the DC voltmeter. Reduce the injection level +23 dBu and confirm less than 3.4 V.

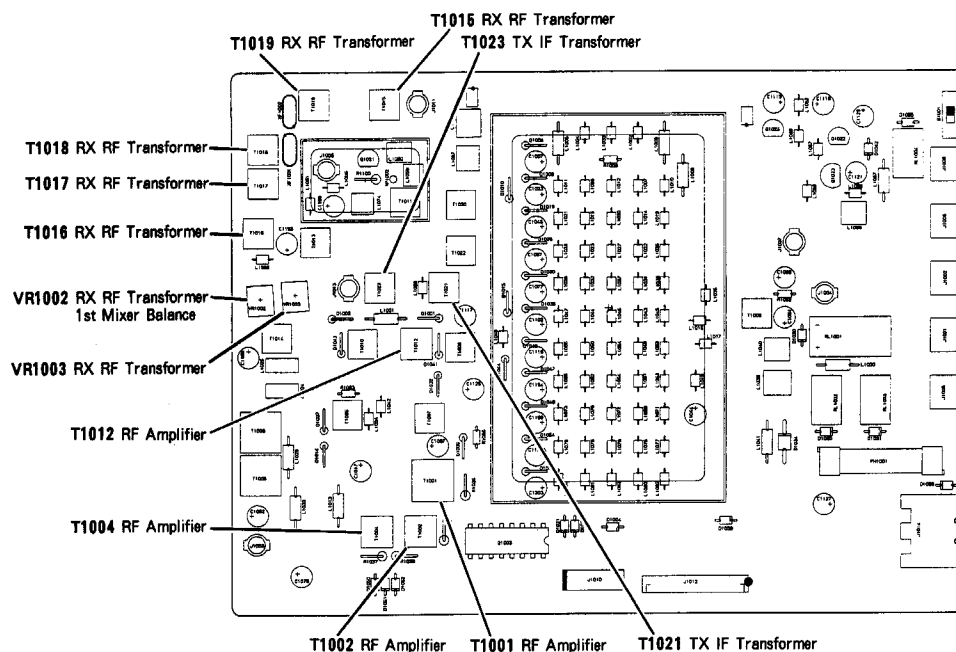

RF Unit Test & Alignment Points

Alignment

Local Unit

Refer to the photograph at the page bottom for LOCAL Unit component locations and alignment points.

2nd Local Oscillator

- Connect the RF millivoltmeter to the TP4002, and adjust T4001 for maximum indication on the RF millivoltmeter (at least 400 mVRMS).
- Replace the RF millivoltmeter with a frequency counter, and adjust T4001 for 62.240 MHz (± 200 Hz).

2nd Local Oscillator Amp

- Remove the coaxial plug from J4002, and connect a 50- Ω resistor in parallel with the RF millivoltmeter across the socket.
- Adjust T4006 and T4007 in succession several times for peak RF millivoltmeter indication (at least 170 mVRMS).
- Remove the meter and resistor, and replace the plug in J4002.

WIDTH DDS Amp

- Connect the RF millivoltmeter to the TP4004, and adjust T4010 for maximum indication on the RF millivoltmeter (at least 70 mVRMS).

3rd Local Amp

- Remove the coaxial plug from J4003 and connect a 50- Ω resistor in parallel with the RF millivoltmeter across the socket.
- Adjust T4008 and T4009 in succession several times for peak RF millivoltmeter indication (at least 100 mVrms).
- Replace the RF millivoltmeter with a frequency counter, and confirm at 8.670 MHz (± 30 Hz).
- Remove the frequency counter and resistor, and replace the plug in J4003.

PLL BPF (67.98 MHz)

- Connect the RF millivoltmeter to TP4001, and adjust T4002~T4005 in succession several times for peak RF millivoltmeter indication (at least 100 mVRMS).

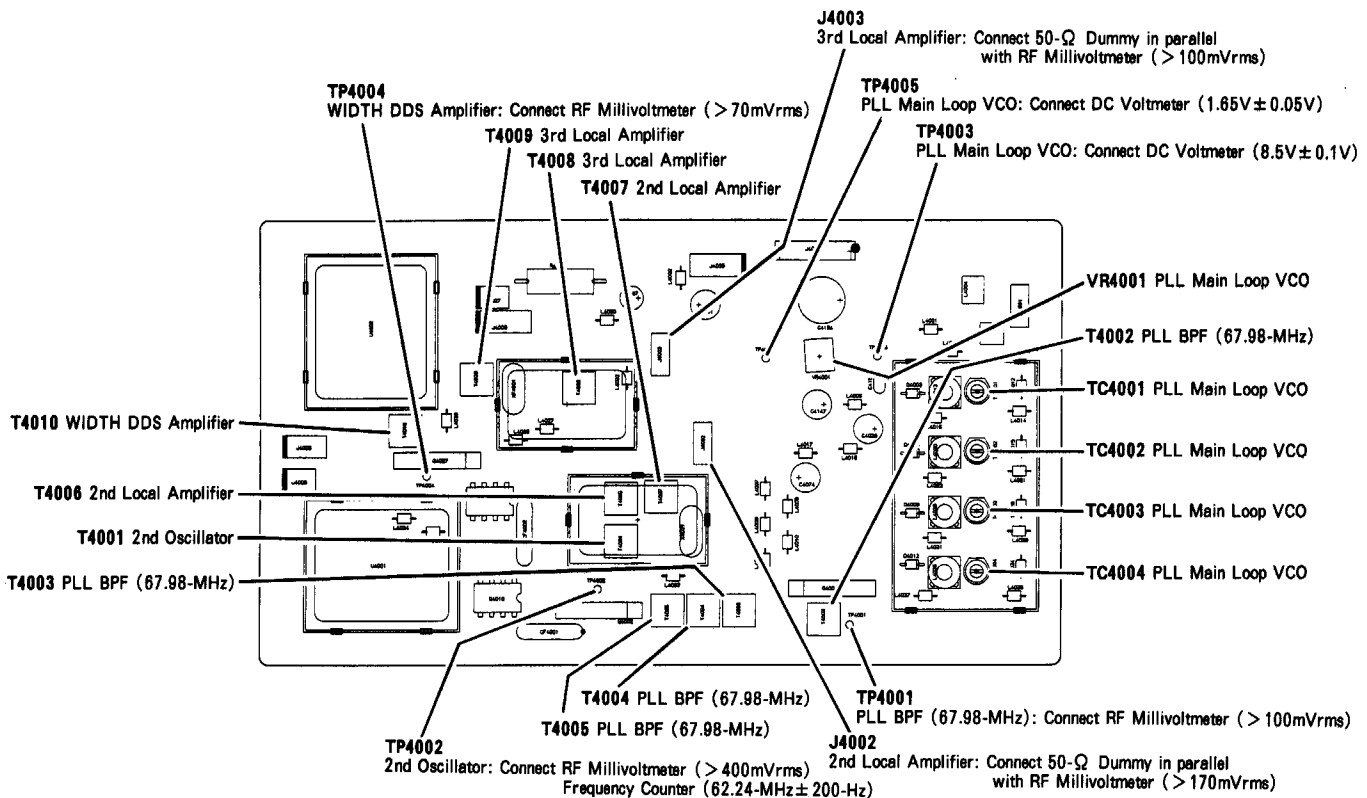

LOCAL UNIT Test & Alignment Points

PLL Main Loop VCO

- Preset VR4001 to the 12-o'clock position, and connect the DC voltmeter to the TP4003.
- Referring to table below, tune the transceiver to each frequency, then confirm or adjust the listed component for the required voltage.

PLL Main Loop VCO Alignment		
Tune to:	Adjust/Confirm	for
7.499 MHz	adjust TC4001	$8.5 \pm 0.1V$
4.000 MHz	confirm	$2.4 \pm 1.1V$
3.999 MHz	confirm	$7.5 \pm 0.1V$
0.100 MHz	confirm	$2.0 \pm 0.5V$
14.499 MHz	adjust TC4002	$8.5 \pm 0.1V$
7.500 MHz	confirm	$1.8 \pm 0.5V$
21.999 MHz	adjust TC 4003	$8.5 \pm 0.1V$
14.500 MHz	confirm	$1.8 \pm 0.5V$
30.000 MHz	TC4004	$8.5 \pm 0.1V$
22.000 MHz	confirm	$1.8 \pm 0.5V$

- Tune the transceiver display to 14.200 MHz. Connect the DC voltmeter to the TP4005, and adjust VR4001 for $1.65V (\pm 0.05V)$ on the DC voltmeter.

PA Unit

Refer to the photograph below for PA Unit component locations and alignment points.

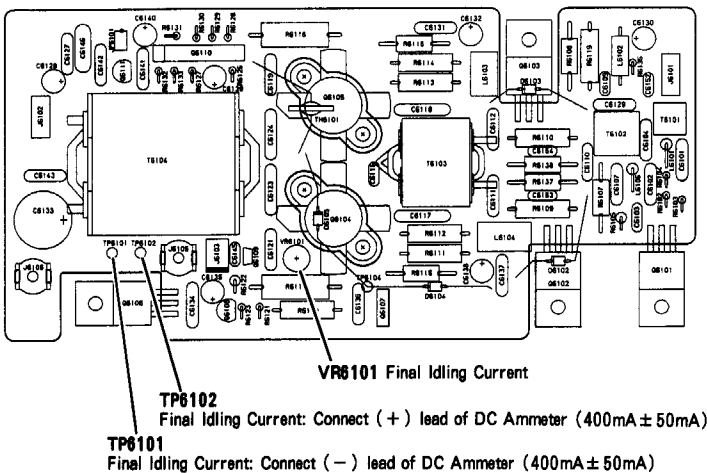

PA Unit Test & Alignment Points

Final Idling Current

- Temporarily disconnect the jumper between TP6101 and TP6102, and connect an ammeter in its place.
- Key the transmitter in either USB or LSB, then, with no microphone input, adjust VR6101 for 400 mA ($\pm 50 mA$). Reinstall the jumper.

LPF Unit

Refer to the photograph below for LPF Unit component locations and alignment points.

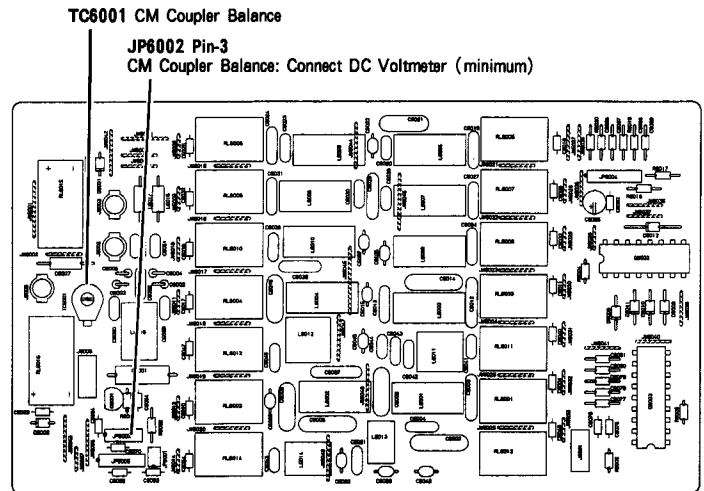

LPF Unit Test & Alignment Points

CM coupler balance

- Connect the DC voltmeter to pin 3 of JP6002, connect a 50-Ω dummy load to the antenna jack, and select CW mode.
- Key the transmitter and adjust TC6001 for minimum indication on the DC voltmeter.