

# ALINCO

VHF FM HANDHELD TRANSCEIVER

# DJ-G1T/G1E

## INSTRUCTION MANUAL

### ALINCO, INC.

Head Office: "TWIN 21" MID Tower Building 23F  
1-61, 2-Chome, Shiromi, Chuo-ku, Osaka 540 Japan  
Phone: 06-946-8150 Fax: 06-946-8175 Telex: 63086

E-mail: 101243.1446@compuserve.com

U.S.A.: 438 Amepola Ave., Unit 130, Torrance, CA 90501, U.S.A.  
Phone: 310-618-8616 Fax: 310-618-8758  
<http://www.alinco.com/>

Germany: Eschborner Landstrasse 55, 60489 Frankfurt am Main, Germany  
Phone: 069-786018 Fax: 069-789-60766

Thank you for purchasing this **ALINCO** transceiver.

To obtain optimum performance from this transceiver, read this Instruction Manual thoroughly, and keep it for future reference. The LCD display examples in this Instruction Manual use the DJ-G1T's LCD display.

# TABLE OF CONTENTS

<b>1. INTRODUCTION</b> .....	1
1-1 Cautions.....	1
1-2 Before Transmitting.....	1
<b>2. ACCESSORIES</b> .....	2
Accessory Attachment and Battery Installation.....	2~3
<b>3. SPECIFICATIONS</b> .....	4
<b>4. PANEL DESCRIPTION</b> .....	5
4-1 Top View.....	5
4-2 Front, Back and Side Views.....	6
4-3 Display.....	8
4-4 Keypad.....	10
<b>5. BASIC OPERATION</b> .....	11
5-1 Receiving.....	11
5-2 Transmitting.....	12
5-3 Main Band and Sub Band.....	13
5-4 Setting a Frequency in VFO Mode.....	14
<b>6. MEMORY MODE AND CALL MODE</b> .....	18
6-1 Using Memory Channels.....	18
6-2 Using the Call Channel.....	21
<b>7. OTHER FUNCTIONS</b> .....	22
7-1 Scanning.....	22
7-2 Channel Scope.....	25
7-3 Priority Watch.....	32
7-4 Offset Direction and Frequency.....	34
7-5 Tone Encoder and Tone Frequencies.....	35
7-6 Reverse Function.....	36
7-7 Split Function.....	36
7-8 Display Lamp.....	39
7-9 Key Lock and PTT Lock.....	39
7-10 Auto Power Off.....	40
7-11 Battery Indicator.....	40
7-12 Battery Save Function.....	41
7-13 Beep Tones.....	41
7-14 DSQ (DTMF Squelch).....	42
7-15 Dial Function.....	50
7-16 Resetting the CPU.....	53
<b>8. OPTIONAL FUNCTIONS</b> .....	54
8-1 Tone Squelch.....	54
<b>9. TROUBLESHOOTING</b> .....	56
<b>10. OPTIONS</b> .....	56
<b>11. Ni-Cd BATTERY PACK</b> .....	57 ~ 59

## 1-1 CAUTIONS

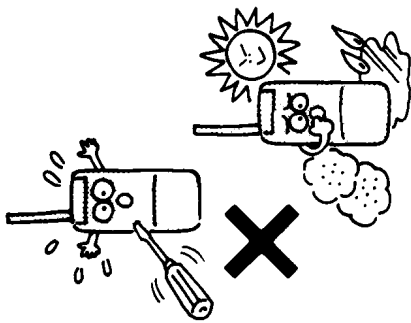

- Never open the transceiver case or touch internal components.
- Be sure to install the batteries with the correct polarity.
- Be sure to attach the flexible antenna securely.
- Avoid using the transceiver in excessively hot, humid or dusty environments.

## 1-2 BEFORE TRANSMITTING

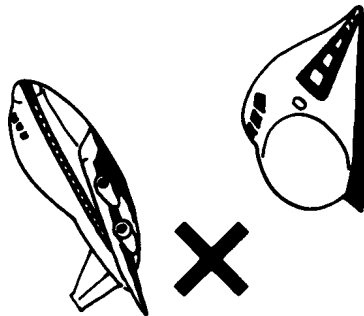

There are many commercial and business related stations located near the ham bands. When operating an amateur station it is important to observe all the proper rules of conduct and not to cause harmful interference to other stations, especially during mobile operation.

In particular, be sure to obtain the proper approval, when operating your transceiver in the following locations: aboard ships or aircraft, in the vicinity of airports, aboard trains, near commercial stations, and near commercial repeaters.

## ACCESSORY ATTACHMENT

(1) Flexible antenna

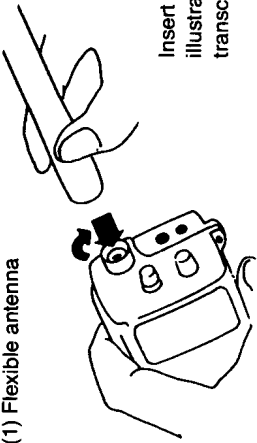

Insert the flexible antenna into the antenna connector as illustrated, then rotate the antenna clockwise to attach it to the transceiver.

(2) Belt clip

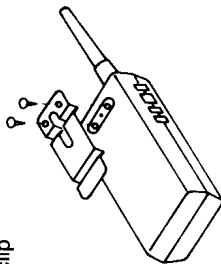

Attach the belt clip to the rear of the transceiver using the supplied screws as illustrated.

(3) Hand strap

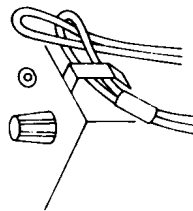

### 3. SPECIFICATIONS

	DJ-G1E	DJ-G1T
RECEIVING FREQUENCY	108.000 – 173.995 MHz 440.000 – 449.995 MHz	144.000 – 145.995 MHz 430.000 – 439.995 MHz
TRANSMIT FREQUENCY	144.000 – 147.995 MHz	144.000 – 145.995 MHz
MODULATION	F3E (receive only: A3)	F3E
ANT. IMPEDANCE	50Ω	50Ω
ANT. CONNECTOR	BNC	BNC
POWER SUPPLY VOLTAGE	7.2 – 12.0 VDC max. 13.8 VDC	7.2 – 12.0 VDC max. 13.8 VDC
TX CURRENT @ 7.2 VDC HI/MID/LOW @ 13.8 VDC HI	approx. 1.0A/0.8A/0.4A approx. 1.6A	approx. 1.0A/0.8A/0.4A approx. 1.6A
RX CURRENT @ AF200mW 8Ω squelched battery save mode	approx. 120 mA approx. 55 mA approx. 25 mA ave.	approx. 120 mA approx. 55 mA approx. 25 mA ave.
FREQUENCY STABILITY	± 5 p.p.m.	± 5 p.p.m.
BODY DIMENSIONS W x H x D	50 x 116 x 37 mm	50 x 116 x 37 mm
BODY WEIGHT	360 gr.	360 gr.
OUTPUT	HI approx. 5W (13.8 VDC) 1.5W (7.2 VDC) MID approx. 1W LOW approx. 0.2W	HI approx. 5W (13.8 VDC) 1.5W (7.2 VDC) MID approx. 1W LOW approx. 0.2W
MODULATOR	VARIABLE REACTANCE	VARIABLE REACTANCE
MAX DEVIATION	± 5 kHz	± 5 kHz
SPURIOUS	not more than – 60dB	not more than – 60dB
MIC IMPEDANCE	2 kΩ	2 kΩ
RECEIVING SYSTEM	DOUBLE CONV. SUPER-HETERODYNE	DOUBLE CONV. SUPER-HETERODYNE
IF 1st/2nd	30.85 MHz/455 kHz	30.85 MHz/455 kHz
SENSITIVITY (12dB SINAD)	TX band centre max. – 16dB $\mu$ RX subband centre (about 440 MHz) max. – 10dB $\mu$	TX band centre max. – 16dB $\mu$ RX subband centre (about 440 MHz) max. – 10dB $\mu$
SELECTIVITY	– 6dB – 60dB	not less than 12 kHz not more than 30 kHz
SPURIOUS RATIO	more than – 60dB	more than – 60dB
AF OUTPUT (@10% distortion)	min 200mW 8Ω	min 200mW 8Ω

#### BATTERY CASE ATTACHMENT

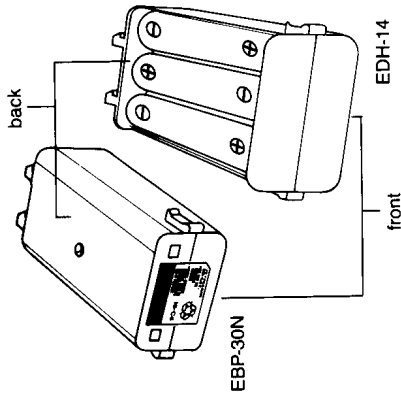

As illustrated in the diagram on the left, align the battery case with the transceiver so that the battery case projections face the rear of the transceiver. Insert the battery case into the transceiver (A) until you hear a click.

Caution: The battery case cannot be inserted in reverse. Never attempt to force it in.

#### Battery pack removal

Push and hold the battery case release button to the right (B), then slide the battery case out of the transceiver.

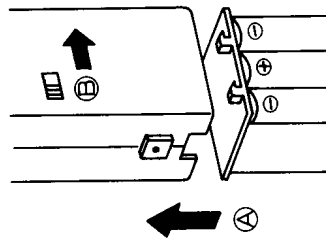

**ATTENTION:** The Alinco Ni-Cd battery is recyclable. At the end of its useful life, under various state and local laws, it may be illegal to dispose of this battery into the municipal waste stream. Check with your local solid waste officials for details in your area for recycling options or proper disposal.

#### Ni-Cd



#### Increasing battery life...

- Turn the battery save function on. (page 41)
- When not in use, turn the power off.
- You can set the Auto Power Off Function so that the transceiver automatically turns off if you forget to turn the power off yourself (page 40).
- Keep transmission time as short as possible.
- Use Low Power Mode for communication over short distances. (page 12)

# 4. PANEL DESCRIPTION

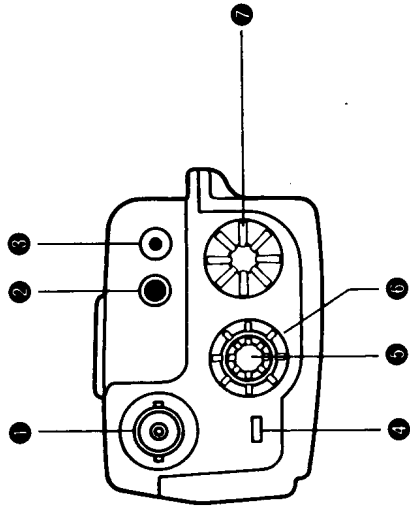
## 4-1 TOP VIEW



		Page
1	<b>BNC Antenna Connector</b>	2
2	<b>Speaker Jack</b>	—
3	<b>MIC Jack</b>	—
4	<b>ON AIR/BUSY Lamp</b>	11 12
5	<b>ON/OFF Volume Control</b>  <b>VOL</b>	11
6	<b>Squelch Control</b> 	11
7	<b>Dial</b> 	14

## 4-2 FRONT, BACK, AND SIDE VIEW

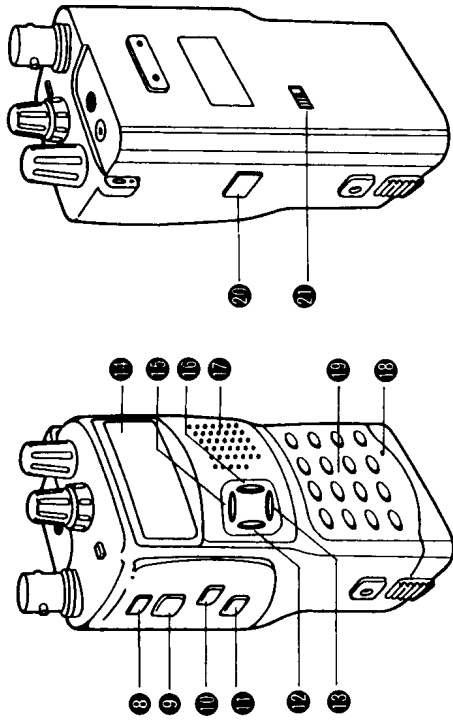

		Page
8	<b>Function [F] Key</b>	10
9	<b>PTT (Press to Talk)</b>	12 50 ~ 52
10	<b>DJ-GIT, Low PTT • AM Key</b>	Press this key to transmit in low power. Press and hold the [F] key and press this key to receive AM signals. Repeat the same procedure to go back to FM mode.
	<b>DJ-GIE, TONE BURST • AM Key</b>	Press this key to emit 1750 Hz tone burst. Press and hold the [F] key and press this key to receive AM signals.* Repeat the same procedure to go back to FM mode. (*This feature available in a certain version only)
11	<b>MONI • BS • BEEP Key [MONI]</b>	Press this key to disengage squelch. Release the key to reengage squelch. Press and hold the [F] key and press [MONI] key for Battery Save function.
12	<b>CALL • BAND Key</b>	Press this key to immediately QSRY to CALL Channel. Press and hold the [F] key and press this key to change the receiving band.

### 4-3 DISPLAY

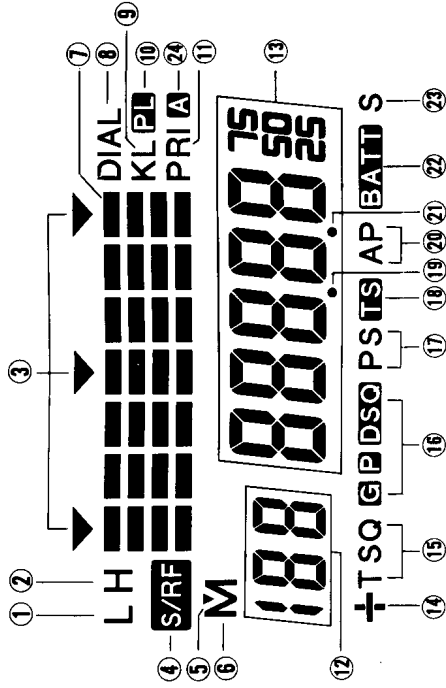

Page

①	L	Appears when in LOW Power Mode.	12
②	H	Appears when in HIGH Power Mode.	12
③	▼	All three appear during SPLIT Mode operation; only one appears during channel scope operation.	25 ~ 31 37, 38
④	S/RF	Appears during transmit or when the squelch is open.	11 12
⑤	▼	Appears to indicate a skipped memory channel during memory scan. Also, appears during DSQ code setting to indicate a code that allows reception.	24 44
⑥	M	Appears when in Memory Mode.	18 ~ 20
⑦	████████	Indicates received signal strength and output power level.	10 11 24 ~ 30
⑧	DIAL	While this appears, pushing the [F] key and transmitting outputs an auto dial memory code.	50 ~ 52
⑨	KL	Appears when the Key Lock is activated.	39 40
⑩	PL	Appears when the [PTT] Key Lock is activated.	

Page

●	V/M-MW Key	Press the <sup>MW</sup> key, key, ▼ and M will appear alternately on the LCD. ▼ indicates that the unit is in the VFO mode and M indicates that the unit is in the memory mode. Press and hold the [F] key and press the <sup>MW</sup> key to write a frequency and other data into the Memory Channel.	18 ~ 20
●	LCD	_____	8 9
●	LAMP-SPLIT Key	Press this key; The LCD read out will be lit for 5 seconds. Press and hold the [F] key and press the LAMP key to bring into split operation mode.	37 ~ 39
●	SCAN-PO Key	Press this key to start SCAN function. Press and hold the [F] key and press this to change transmission power.	12 22 ~ 24
●	Speaker	_____	—
●	Microphone	_____	—
●	Keyboard	Use this keyboard to enter frequency, DSQ; and other functions in combination with [F] key.	10
●	DC-IN	This jack is for accessing the outside 13.8 V power source.	—
●	Battery release knob	_____	3

On the transceiver body, key-functions printed in blue indicate the secondary functions (accessed with [F] key).

## 4-4 KEYPAD

		Page	
①	<b>PRI</b>	Appears during Priority Watch.	32 33
⑫	<b>!88</b>	Indicates the selected memory channel No.	18 ~ 20
⑬	<b>88888</b>	Indicates the transmit/receive frequency, offset frequency, tone frequency, tuning step, DSQ code and DIAL code.	—
⑭	<b>+</b>	Indicates the offset direction (+, -).	34
⑮	<b>TSQ</b>	Appears when the tone encoder or tone squelch function is activated.	35 36 54 55
⑯	<b>DSQ</b>	Appears during DSQ operation.	42 ~ 49
⑰	<b>PS</b>	Appears during scanning to indicate a program scan.	23 30
⑱	<b>TS</b>	Appears during scanning to indicate a timer scan. This indicator also appears when the power is first turned on.	22 ~ 24 29 30
⑲	<b>88888</b> <small>75 50 25</small>	The MHz decimal point for transmit/receive and offset frequencies. Flashes during scanning.	
⑳	<b>AP</b>	Appears when Auto Power Off is activated.	40
㉑	<b>8888</b>	The Hz decimal point when a tone frequency is displayed.	35 55
㉒	<b>BATT</b>	Appears to indicate a low battery condition.	40
㉓	<b>S</b>	Appears when the Battery Save Function is activated.	41
㉔	<b>A</b>	Appears when in AM receiving mode.	—

	Without pushing [F]	While pushing [F]	Page
<b>TO</b>	Inputs the 1 digit	Tone encoder/decoder, tone frequency setup	35 36 54 55
<b>OFF</b>	Inputs the 2 digit	Offset direction, offset frequency setup	34
<b>REV</b>	Inputs the 3 digit	Offset, split reverse operation	37 38
<b>WAIT</b>	Inputs the 4 digit	Sets the delay time for DSQ code output	49
<b>SKIP</b>	Inputs the 5 digit	Memory skip	24
<b>SEARCH</b>	Inputs the 6 digit	Channel scope	25 ~ 31
<b>KL/PL</b>	Inputs the 7 digit	Key lock, PTT lock	39 40
<b>TMR</b>	Inputs the 8 digit	Time scan setting	22
<b>AP</b>	Inputs the 9 digit	Auto power off setting	40
<b>STEP</b>	Inputs the 0 digit	Tuning step setting	17
<b>MRV</b>	Decrements frequency/ memory No.	Decrements memory No. in VFO Mode	15 19
<b>MRV</b>	Increments frequency/ memory No.	Increments memory No. in VFO Mode	18
<b>PS</b>	Activates Priority Watch	Program scan	32 33
<b>DIAL M</b>		Auto dial setting	50 ~ 52
<b>MRV</b>	Reinputs 1 digit of the frequency	Memory shift	20
<b>DSQ SET</b>	DSQ Mode set	DSQ code set up	42 ~ 49

- While pushing **PTT**, push a key in the keypad to output a DTMF code.
- Push and hold **MRV** or **MRV** to change the frequency or memory channel continuously.

# 5. BASIC OPERATION

## 5-1 RECEIVING PROCEDURE

### 1. Turn the power on and adjust the audio volume

Rotate the **[VOL]** knob clockwise to turn the power on, and increase the audio output. Adjust the audio volume to a suitable level.

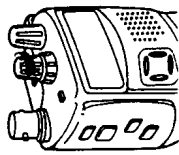

### 2. Adjust the squelch

Slowly rotate **[SQL]** clockwise to the point where the audio noise just disappears.

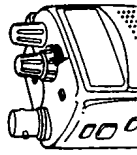

### 3. Set a frequency

Refer to 4-4 "Setting a Frequency in VFO Mode", to set the frequency you desire. When a signal is received, audio is emitted from the speaker.

## 5-2 TRANSMIT PROCEDURE

### 1. Set a frequency

Refer to 4-4 "Setting a frequency in VFO Mode", and set a frequency.

### 2. Transmit

Push and hold the **[PTT]** key, then speak into the microphone.

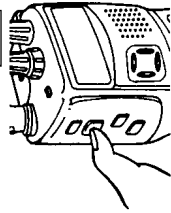

The ON AIR lamp lights red during transmission.

Release the **[PTT]** key to stop transmitting and return to receive.

## SELECTING OUTPUT POWER

You can choose between three output power levels.

While pushing **[F]**, push **[SCAN]**.

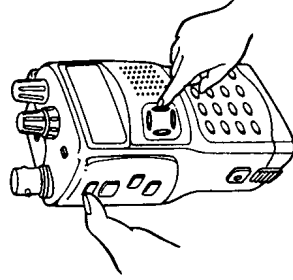

Each push changes the setting. The transmit display changes according to the power level you have selected.

## RECEIVE INDICATORS

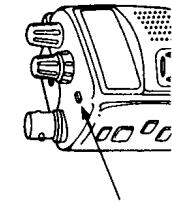

① The BUSY lamp lights green.

② The S/RF indicator lights, and the strength of the received signal is indicated on the S meter.



## RECEIVING WEAK SIGNALS

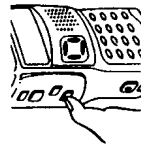

Push the **[MONI]** key. This opens the squelch and helps you copy weak or intermittent signals more clearly.

## TRANSMITTING AT LOW POWER (DJ-G1T)

### LOW BURST (DJ-G1E)

DJ-G1T: To transmit at low power regardless of the currently set power level.  
DJ-G1E: Push the **[TONE BURST]** key to output a 1750 Hz tone.

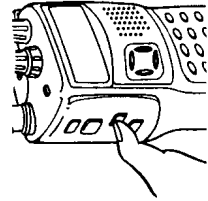

DJ-G1T:

Push the **[LOW PTT]** key to transmit at low power and release **LOW PTT** to return to the previous setting.

DJ-G1E:

Push the **[TONE BURST]** key to output a 1750 Hz tone.

During transmission

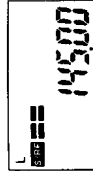



## 5-3 MAIN BAND AND SUB BAND

The DJ-G1 each has two operating bands, a main and a sub band. The main band can be used for both transmit and receive while the sub band can be used for receive only.

DJ-	Main Band TX RX	Sub Band RX
European Version	TX: 144.000 ~ 145.995 FM RX: 144.000 ~ 145.995 FM	430.000 ~ 439.995 FM
U.S. Version	TX: 144.000 ~ 147.995 FM RX: 108 ~ 173.995 AM/FM	440 ~ 449.995 AM/FM

(unit: MHz)

### SUB BAND RECEIVE

- Push  $\frac{MW}{V/M}$  to select VFO Mode.  
If M or C appears, push  $\frac{MW}{V/M}$  one or more times to select VFO Mode.

- While pushing **F**, push  $\frac{CALL}{BAND}$ .

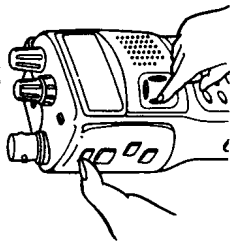

Sub band receive is selected.

14500

44500

**To cancel** Repeat the above operation to return to main band operation.

### Sub band operation

- Pushing **PTT** does not transmit; instead "OFF" is displayed.
- Tone setting, offset, or DSQ setting cannot be performed.
- An invalid operation beep in low-tone sounds if any of these operations are attempted.

## 5-4 SETTING A FREQUENCY IN VFO MODE

This transceiver has three operating modes: VFO Mode, Memory Mode and Call Mode. When the power is first turned on, the transceiver is in VFO Mode. In VFO Mode it is easy to change frequencies and set the various functions. There are three methods for setting a frequency in VFO Mode: with the dial, the UP/DOWN keys or by direct keypad entry.

### USING THE DIAL

#### 1. Select VFO Mode

If a mode other than VFO Mode is selected, refer to "Changing operating modes" below and set to VFO Mode.

145000

In VFO Mode, no C or M appears to the left of the frequency.

#### 2. Changing the frequency in channel step units

Each click of the dial changes the frequency in the selected channel step unit.

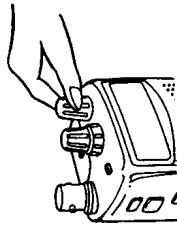

Clockwise rotation increases the frequency, and counterclockwise rotation decreases it. The default channel step unit is 5 kHz for the G1T and 12.5 kHz for the G1E. Refer to page 17 regarding changing the channel step unit.

#### 3. Changing in 1 MHz steps

Rotate the dial while pushing the **F** key to change the frequency in 1 MHz steps.

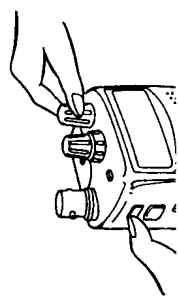

Clockwise rotation increases the frequency, and counterclockwise rotation decreases it.

### CHANGING OPERATING MODES

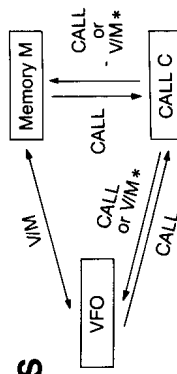

\* Returns to the mode selected before CALL C.

## USING THE UP/DOWN KEYS TO SET THE FREQUENCY

### 1. Select VFO Mode

Refer to page 14 "Changing operating modes".

### 2. Increasing by channel step units

Push the  key to increase the frequency by the channel step unit.

e.g. when the channel step is 20 kHz.

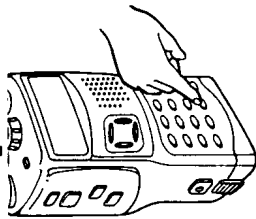

145.00

145.02

### 3. Decreasing by channel step units

Push the  key to decrease the frequency by the channel step unit.

e.g. when the channel step is 20 kHz.

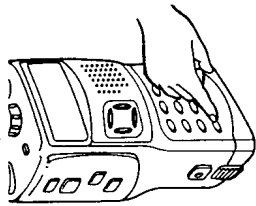

145.00

144.98

## DIRECT KEYPAD ENTRY

### 1. Select VFO Mode

Refer to page 14 "Changing operating modes".

### 2. Input a frequency

e.g. Setting 144.005 MHz with a channel step of 5 kHz.

Starting from the 100's of MHz digit, enter **1**, **4**, **4**, **0**, **0**, **5**.

After inputting the 1 kHz digit a slightly longer beep is emitted to signal that input is complete.

144.005



(Sub band frequencies can also be set using direct keypad entry.)

**Note:** When inputting a frequency, keys must be pushed within 5 seconds of one another, or inputting will be aborted and the frequency will revert to the previous one. Listen for the beep to confirm that your input was accepted.

## ! INPUTTING BY CHANNEL STEP

- 5 KHz Input to the 1 kHz digit. If a 1 kHz digit other than **5** is input, it becomes 0.
- 10 KHz Input to the 10 kHz digit.
- 12.5 KHz Input to the 10 kHz digit. **4** and **9** are invalid keys for the 10 kHz digit.
- 15 KHz Input to the 1 kHz digit. If a 1 kHz digit other than **5** is input, it becomes 0.
- 20 KHz Input to the 10 kHz digit.
- 25 KHz Input to the 10 kHz digit. **0**, **2**, **5** or **7** only can be input as the 10 kHz digit.
- 30 KHz Input to the 10 kHz digit.
- 50 KHz Input to the 10 kHz digit.

## ! CANCELLING AN INPUT

While inputting a frequency, push the  key to reinput the last-input digit. Pushing **[PTT]** or  or  cancels everything and returns to the previously set frequency. Also, when a period of longer than 5 seconds elapses between keypad input, the transceiver returns to its previously set frequency.

## ! FREQUENCY CORRECTION

When changing the channel step or when entering a frequency directly, the frequency is automatically adjusted (UP/DOWN) to coincide with the channel step.

e.g. When the frequency has been set to 145.215 MHz with a channel step of 5 kHz, and the channel step is changed to 10 kHz, the frequency is changed to 145.22 MHz if the frequency is changed by 1 step upwards.

# 6. MEMORY MODE AND CALL MODE

## 6-1 USING MEMORY CHANNELS

Memory channels are useful for storing often-used frequencies and settings for easy recall. The following memory channels are available.

Memory channel No.	Contents
ch 0 ~ 79	Memory channels
H, L	Program scan edge frequencies
C	Call channel

Programmable memory information

- ① Receive frequency
- ② Offset direction
- ③ Offset frequency
- ④ Tone setting/frequency
- ⑤ DSQ setting

### CALLING UP MEMORY CHANNEL INFORMATION

#### 1. Select Memory Mode



While in VFO Mode, push .

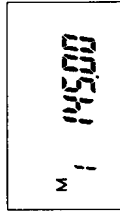

The transceiver enters Memory Mode and M and the memory channel No. appear.



#### 2. Select the memory channel No.

Use the dial or the  /  keys to select the memory channel No.









Order of selection

ch 1 → 79 → C



ch 0 ← H ← L

(Order is reversed when pushing DOWN)

	UP	DOWN
1 ch steps	 / 	 / 
10 ch steps	While pushing  	While pushing  

The M display

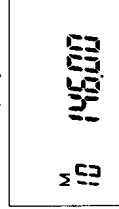

When M is displayed, the programmed memory information is displayed.

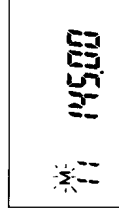

When M flashes, memory information has not been programmed. VFO information is displayed.



When C, L or H appear, the UP/DOWN switches cannot be used to change the channel in steps of 10.

## CHANGING CHANNEL STEPS

The channel step frequency is the basic unit of frequency change for the VFO frequency, offset frequency (page 34), scanning (page 22) and channel scope operation (page 25). The default channel step is 5 kHz for the G1T and is 12.5 kHz for the G1E.

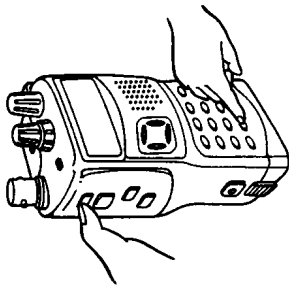

- ① In VFO Mode, while pushing , push .





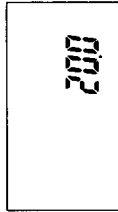





The transceiver enters Channel Step Changing Mode and the present channel step is indicated. (unit: kHz)

This setting is separate for the main and sub bands.



- ② Use the dial or  /  keys to select the desired channel step.

 5.0 |  10.0 |  12.5 |  15.0 |  20.0 |  25.0 |  30.0 |  50.0 (kHz)

**Completion** Push either of  /  ,  plus  , or  .  
For main band only Push  plus  to enter tone setting mode; push  plus  to enter offset setting Mode.

**Note:** These operations are not possible in Memory or Call Modes. If attempted a low-tone beep will sound to indicate an invalid operation.

## PROGRAMMING DATA INTO THE MEMORY CHANNELS

When the transceiver is shipped from the factory, memory channels 0 to 79 are empty. Before using a memory channel, you must program information into it.

### 1. Set a frequency

In VFO Mode, set a frequency you want to program. If desired, set an offset direction, offset frequency and tone frequency as well.

### 2. Select a memory channel

While pushing **[F]**, push **M** / **M** to select a memory channel (M flashes).

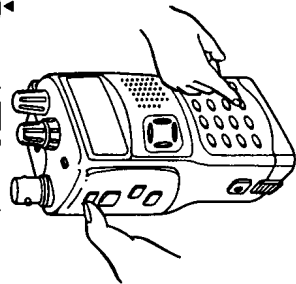

In VFO Mode, while pushing the **[F]** key, the memory channel No. appears.

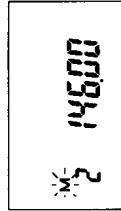

### 3. Program the memory

While pushing **[F]**, push **M** / **M**.

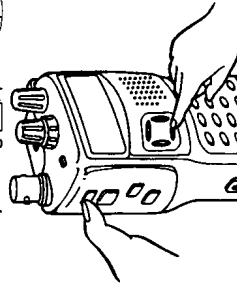

A completion beep sounds and programming is completed. M appears while pushing **[F]** and disappears when **[F]** is released. Old data that was previously programmed will be overwritten.

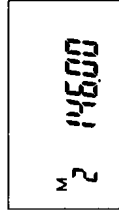

## PROGRAMMING IN MEMORY MODE

In Memory Mode, when M flashes (indicating an unprogrammed memory channel), push and hold **[F]** then push **M** / **M** to program the displayed data into the selected memory channel. M stops flashing.

## ERASING MEMORY INFORMATION

1. Select Memory Mode
2. Select a memory channel

Choose the programmed memory channel (M is displayed) that you wish to erase.

### 3. Erase the information

While pushing **[F]**, push **M** / **M**.

The information is erased and a confirmation beep sounds. M flashes and the programmed information such as frequency, etc. remain displayed. Repeat the above step to reprogram the information.

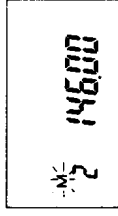

**Note:** If the channel is changed or another mode is selected after erasing memory information, the erased information cannot be recalled, VFO information is displayed instead.

## TRANSFERRING MEMORY INFORMATION TO VFO MODE

In Memory Mode, while pushing **[F]**, push **M** / **M**.

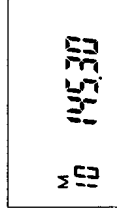
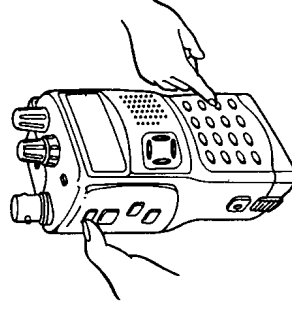

The memory information is copied to VFO and the transceiver enters VFO Mode.

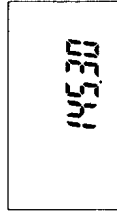

# 7. OTHER FUNCTIONS

## 7-1 SCANNING

Scanning is used to automatically search for signals over a frequency range or among programmed memory channels. There are three types of scan available.

- **Band scan** This scan searches the entire frequency range of the band
- **Program scan** This scan searches over a user-specified range of frequencies only. Scan edge frequencies must be stored in memory channels H (upper limit) and L (lower limit). When scan edge L is greater or equal to scan edge H, a band scan is performed.
- **Memory scan** This scan searches for signals in the memory channels (0 to 79).

The direction of the scan corresponds to the last UP/DOWN switch operation.

### SETTING THE SCAN RESUME CONDITION

Scan pauses while a signal is being received and resumes according to one of two resume conditions. This can be set during a scan.

While pushing **F**, push **TMS** **C**

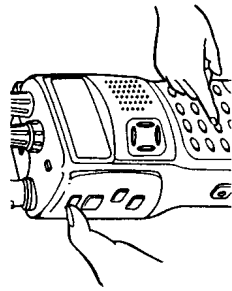

Each push of the key changes the scan resume condition between the two listed beneath.

● **Timer scan**

Scanning resumes 5 seconds after pausing, or when the signal disappears, whichever comes first.

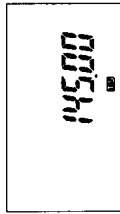

● **Busy scan**

Scanning pauses while receiving a signal and resumes 2 seconds after the signal disappears.

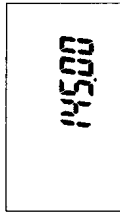

When shipped from the factory, the transceiver is set to timer scan.

### BAND SCAN

The entire range of frequencies comprising the band are searched.

- Start**
- ① Select VFO Mode.
  - ② Push the **PO** **SCAN** key.

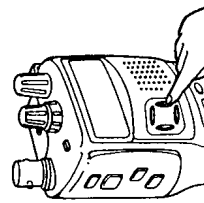

During band scan

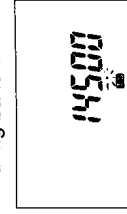

The decimal point flashes and scanning proceeds with the set channel step unit.

- Stop**
- Push either the **MW** **V/M**, **PO** **SCAN**, or **PTT** keys.

## 6-2 USING THE CALL CHANNEL

This mode is used for quick recall of a most-often-used frequency (the call channel). The call channel is programmed into memory channel C (page 18) and is used in the same manner as regular memory channels.

### CALLING UP THE CALL CHANNEL

In VFO or Memory Mode, push the **CALL** **BAND** key.

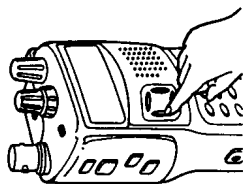

C appears on the display, and the transceiver enters Call Mode.

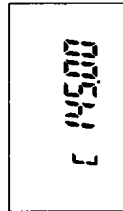

When in Call Mode, push the **CALL** **BAND** key or the **MW** **V/M** key to return to VFO or Memory Mode.

### CHANGING THE CALL CHANNEL FREQUENCY

#### 1. Set the frequency

Set a new call frequency in VFO Mode.

#### 2. Select the C channel

While pushing **F**, push **MRA** **C** or **MRY** **C** until C appears.

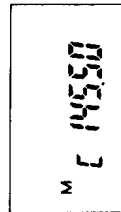
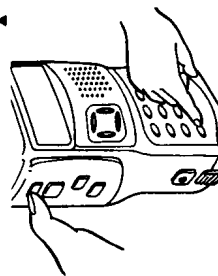

#### 3. Program the memory

While pushing **F**, push **MW** **V/M**.

## PROGRAM SCAN

All frequencies between memory L and memory H are searched.

### 1. Set the lower scan edge (L)

- In VFO Mode, set the lower scan edge frequency.
- While pushing **[F]**, push **[MR/L]** or **[MR/V]** to select memory L.
- While continuing to push **[F]**, push **[MW/VZ/M]**.

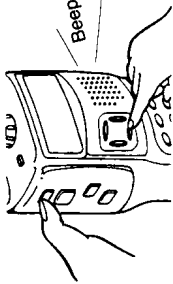

### 2. Set the upper scan edge (H)

Proceed in the same manner as above, selecting memory H instead of memory L.

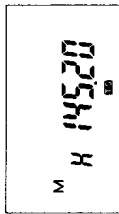

**Note:** Within the selected frequency range, the frequency set in memory H must be greater than the frequency set in memory L. If this is not done, band scanning will take place instead.

### 3. Starting and stopping a scan

- Start** In VFO Mode, while pushing **[F]**, push **[PS/PRI]**.
- During program scan
- 
- PS appears, the decimal point begins to flash, and scan proceeds according to the set channel step unit.
- Stop** Push **[MW/VZ/M]**, **[SCAN]**, **[F]** plus **[PS/PRI]**, or **[PTT]** to stop the scan. PS disappears.

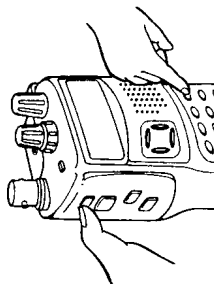

## PROGRAM SCAN RANGE

Whether scan is started at point A, B or C (in the diagram at right) has no effect on the range of frequencies scanned. In each case, range B is scanned.

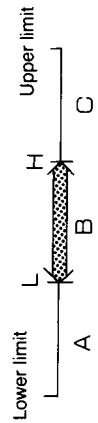

## MEMORY SCAN

- Start** ① Push **[MW/VZ/M]** to enter Memory Mode.

- ② Push **[PS/SCAN]**.

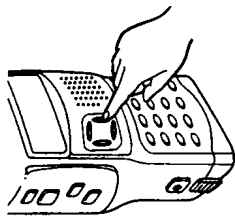

Scan proceeds through programmed memory channel frequencies.

During scan the decimal point flashes.

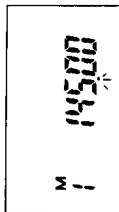

- Stop** Push either **[MW/VZ/M]**, **[SCAN]**, or **[PTT]**.

## SETTING NON-SCAN CHANNELS (SKIP CHANNELS)

Set memory channels not to be scanned during memory scan.

- Select Memory Mode.
- Select a channel to be skipped.
- While pushing **[F]**, push **[SKIP]**.

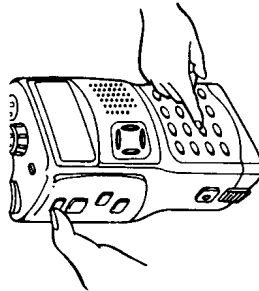

▼ appears above M and the channel is skipped during memory scan.

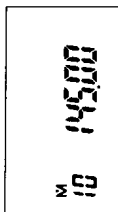
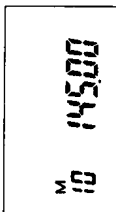

To cancel Repeat the above steps to cancel a skip channel. ▼ disappears.

## SCAN DIRECTION

UP		<b>[MR/V]</b> Key
DOWN		<b>[MR/V]</b> Key

During scanning, change the scanning direction by performing the operations in the above table.

## PRIORITY WATCH DURING SCANNING

Push **[PS/PRI]** during scanning and Priority Watch will operate simultaneously (page 33).

## 7-2 CHANNEL SCOPE

The Channel Scope function allows you to observe the signal reception levels of adjacent channels while receiving on a particular channel.

<Normal receive >

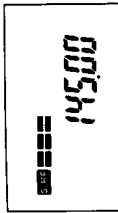

The S meter appears and shows signal strength in 7 segments horizontally.

<During Channel Scope >

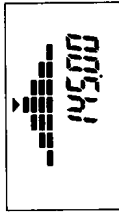

Signal strengths for 7 frequencies are displayed vertically using 4 segments, with the set frequency being in the middle (▼).

- The indicated frequency in numeral is called the center frequency (center channel)
- The level displays for the three frequencies below and the three frequencies above the center frequency. The changes are updated every 5 seconds.

There are two types of channel scope:

- **VFO Channel Scope** The frequencies corresponding to the displayed levels are separated by the channel step unit.
- **Memory Channel Scope** The displayed levels are for the adjacent memory channels.

## VFO CHANNEL SCOPE

### 1. Starting and stopping channel scope

- Start** ① Push to select VFO Mode.  
② While pushing push .

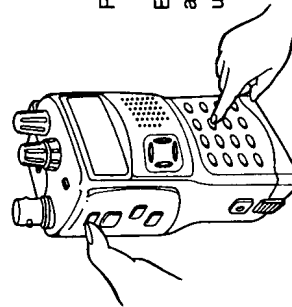

Receiving proceeds in Channel Scope Mode.

Every 5 seconds, the receive levels for the three frequencies below and above (separated by the channel step) the center frequency are updated.

- Stop** Push or and .

## 2. Understanding the receive level indications

e.g. When the channel step is set to 5 kHz

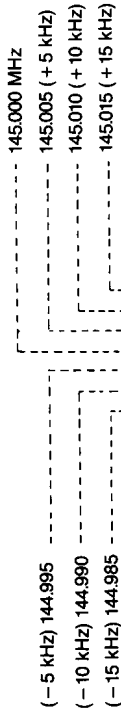

The three frequencies above and the three frequencies below center frequency are each updated every 5 seconds.

- Level indications for frequencies which lie outside of the band are not displayed.

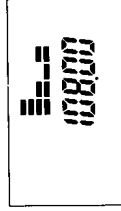

## 3. Changing the center frequency

- Rotate the dial clockwise or push to increase the center frequency by one channel step; rotate the dial counterclockwise or push to decrease the center frequency by one channel step.  
e.g. channel step 20 kHz

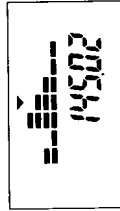
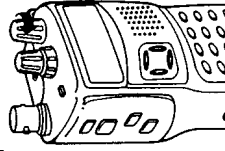

The seven displayed levels shift to the right or left.

- While pushing , rotate the dial clockwise to increase the center frequency by 1 MHz; rotate the dial counterclockwise to decrease the center frequency by 1 MHz.

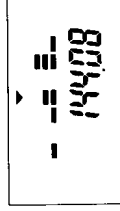
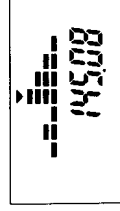
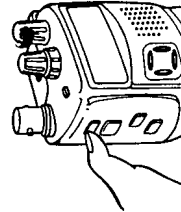

Seven levels are displayed with the new center frequency in the middle.

**Note:** During channel scope operation, frequencies cannot be input using the keypad.

## MEMORY CHANNEL SCOPE

### 1. Starting and stopping channel scope

**Start** ① Select Memory Mode with  $\langle \text{V/M} \rangle$ ; then select a channel when M appears.

② While pushing  $\text{F}$ , push  $\langle \text{SEARCH} \rangle$ .

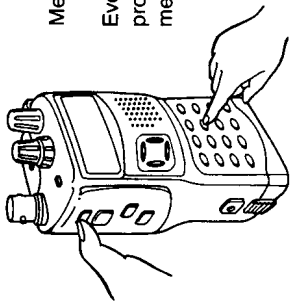

Memory Channel Scope receive proceeds.

Every 5 seconds the receive level indication is updated for the three programmed memories below and the three programmed memories above the center memory channel.

**Stop** Push  $\langle \text{V/M} \rangle$  or  $\text{F}$  and  $\langle \text{SEARCH} \rangle$ .

**Note:**

- An invalid operation beep sounds and Channel Scope operation is not selected when attempting to start Channel Scope while selecting a memory channel which is not yet programmed, a skip channel, or memory channels C, L and H.
- Receive levels for memory channels exceeding the upper and lower limits are not displayed.

### 2. Understanding the level indication

eg. M5 and M6 have no information programmed.

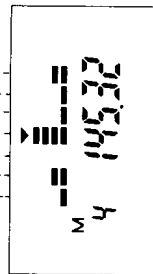
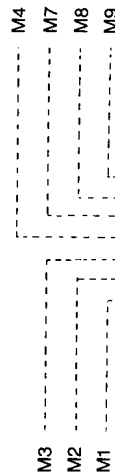

The three receive level displays above and below the center channel are updated every 5 seconds.

- Unprogrammed channels and skip channels are not displayed.

### 3. Changing the center channel

Rotate the dial clockwise or push  $\langle \text{MR} \rangle$  to move the center channel up; rotate the dial counterclockwise or push  $\langle \text{MR} \rangle$  to move the center channel down.

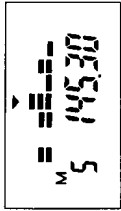
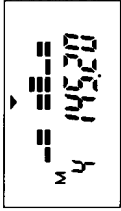
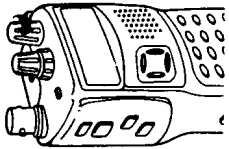

The seven level indicators move to the left or right.

## SCOPE MODE OPERATION

The same procedure applies for VFO Scope and Memory Scope.

### 1. Changing the center frequency (channel) receive interval

The center frequency receive interval is set as 5 seconds from the beginning of scope receiving. However, this can be changed temporarily.

The following keys have the functions described below during scope operation.

$\langle \text{TONE} \rangle$  key

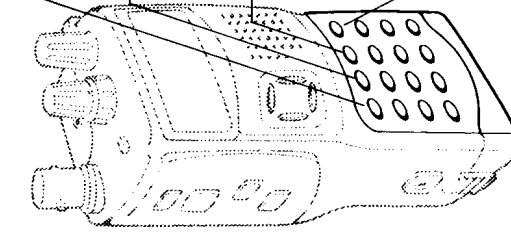

Continuously updates the seven receive level indicators.  
(The audio received at the center frequency cannot be heard)

$\langle \text{OFF SET} \rangle$  key

Receives the center frequency for 3 seconds; then the other 6 receive level indicators are updated.

$\langle \text{REV} \rangle$  key

Receives the center frequency for 5 seconds; then the other 6 receive level indicators are updated.  
(Returns to the initial setting)

$\langle \text{PS/PRI} \rangle$  key

Receives the center frequency continuously.  
The other six receive levels are updated with each push of  $\langle \text{PS/PRI} \rangle$  key.

- When there is no signal for a specified period, the center frequency resumes receiving.
- Receive interval changes remain in effect until scope operation is ended.
- The transceiver returns to 5 second reception at the end of scope operation.



## 2. Transmitting in scope Mode

During scope operation, push and hold **[PTT]** to transmit on the center frequency.

Receiving



While transmitting, the 7 receive level indicators disappear and only the output power of the center frequency is indicated.

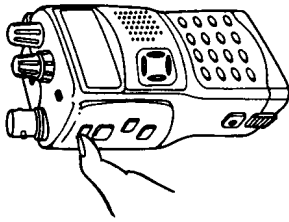

Transmitting

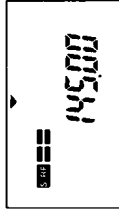

Release **[PTT]** to return to Scope Mode operation.

## ! SCOPE MODE RECEIVE INTERVAL CAUTIONS

- While TSQ (page 35) or DSQ (page 42) is set, the squelch is temporarily opened during channel scope operation.
- While receiving the center frequency, the receive audio may be periodically clipped. This is because every 5 (or 3) seconds the receive levels of the other channels are being updated.

## VFO CHANNEL SWEEP SCAN

Sweep Scan shows each channel's receive level in order while changing frequencies. Audio can not be heard while scanning.

## 1. Starting and stopping band sweep scan

**Start** During VFO Channel Scope, push **[SCAN]**.

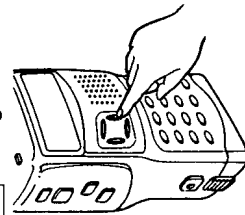

The decimal point flashes and Sweep Scan proceeds in the last operated direction within the band.

**Stop** Push **[SCAN]** or **[PTT]** to return to VFO Channel Scope Mode; push **[V/M]** to return to normal VFO operation.

## 2. Starting and stopping program sweep scan

**Start** In VFO Channel Scope Mode, while pushing **[F]** push **[PS]**.

PS appears, the decimal point flashes and sweep scan proceeds between memory L and memory H.

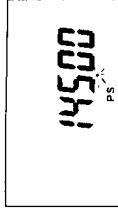
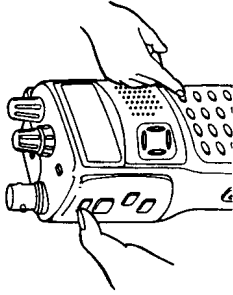

**Stop** Push **[F]** and **[PS]** or push **[SCAN]** or **[PTT]** to return to VFO Channel Scope Mode; push **[V/M]** to return to normal VFO operation.

## 3. Understanding the level indicators

Scan proceeds in the last operated direction.

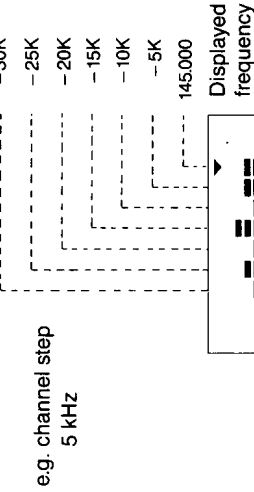

< Scan direction UP >

As the frequency is increased step by step, the receive level display changes accordingly.

< Scan direction DOWN >

As the frequency is decreased step by step, the receive level display changes accordingly.

Scan direction can be changed using the dial or **[MR]** / **[MR]** keys.

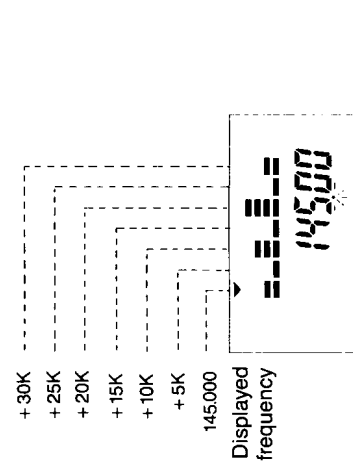

## MEMORY SWEEP SCAN



This scan searches through the memory frequencies.

### 1. Starting and stopping Memory Sweep Scan

**Start** In Memory Channel Scope Mode, push .

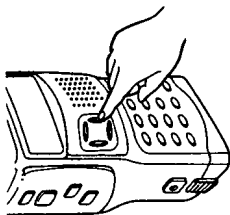
The decimal point flashes and all programmed memories are sweep scanned.

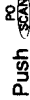

**Stop** Push  or  to stop the scan and return to Memory Channel Scope Mode; push  to stop the scan and return to normal memory operation.

### 2. Understanding the level indicators

Scan proceeds in the last direction operated.

<Scan direction UP >

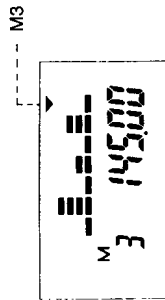

The indicated memory starts at the furthest right, the lowest number, and proceeds through the 6 neighboring memories' receive levels.

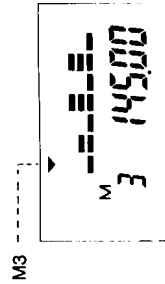

As each channel moves up, the corresponding receive level is displayed.

<Scan direction DOWN >



The indicated memory starts at the furthest left, the highest number, and proceeds through the 6 neighboring memories' receive levels.

As each channel moves down, the corresponding receive level is displayed.





The dial and the  /  keys can be used to change the direction of the scan.

## 7-3 PRIORITY WATCH

The Priority Watch Function monitors a memory frequency every 5 seconds, for 0.5 seconds, while operating on the VFO frequency or vice versa. When a signal is received on the monitored frequency, Priority Watch pauses on that signal for 2 seconds.

### VFO PRIORITY WATCH

In VFO Priority Watch, the transceiver remains in VFO Mode for 5 seconds then monitors Memory Mode for 0.5 seconds

- ① Push  to select VFO Mode, then set a frequency.
- ② While pushing , push  /  to select a memory channel.
- ③ Push .

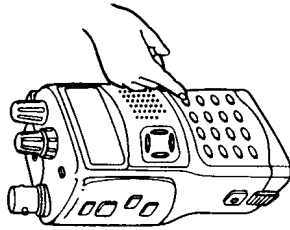

VFO Priority Watch begins.

VFO Mode for 5 seconds

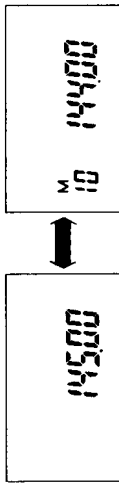



Receiving a signal

When receiving a signal in Memory Mode, a beep sounds and the transceiver pauses for 2 seconds on the signal.

Beep  
2 seconds

### CANCELLING PRIORITY WATCH

The procedure is the same for VFO Priority Watch and Memory Priority Watch.

- While receiving for 5 seconds, push  or  to cancel Priority Watch.
- While receiving for 0.5 seconds, push  to cancel Priority Watch.
- After cancelling Priority Watch, the transceiver enters the mode that the operation was performed in.

**Note:** DSQ is temporarily cancelled during Priority Watch.

## MEMORY PRIORITY WATCH

When Priority Watch is operated in Memory Mode, the transceiver stays in Memory Mode for 5 seconds then monitors VFO Mode for 0.5 seconds.

① Set a frequency in VFO Mode.

② Push to select Memory Mode, then select a memory channel.

③ Push .

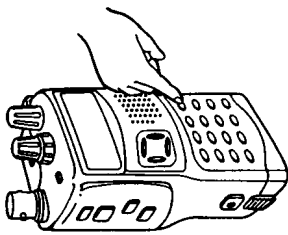

Memory Priority Watch begins.

Memory Mode 5 seconds

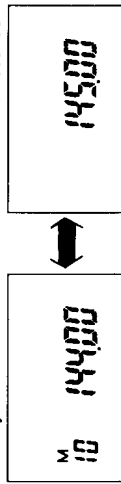

Receiving a signal



When a signal is received in VFO Mode, a beep sounds and the transceiver pauses for 2 seconds on the signal.

Beep 2 seconds

## SIMULTANEOUS PRIORITY WATCH AND SCAN OPERATION

**Start** During the 5 second pause of Priority Watch, press , or while pushing push , to start simultaneous scan operation.

**Stop** To stop both Priority Watch and scan, push .

To stop Priority Watch only, push .

To stop the scan only, push either , , or plus .

**Note:** During Memory Priority Watch, pushing plus has no function.

## 7-4 OFFSET DIRECTION AND FREQUENCY

It is possible to shift the transmit frequency by an offset frequency in either the + or - directions with respect to the receive frequency. (Applicable in main band only)

### SETTING THE OFFSET DIRECTION

While pushing , push .

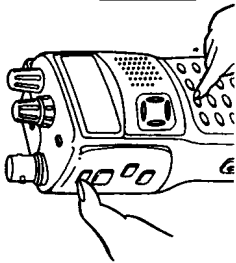

Each push changes the setting as indicated.

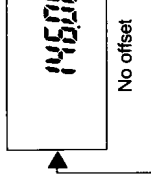

The offset frequency is displayed.

### SETTING THE OFFSET FREQUENCY

Refer to the table at right and set the offset frequency accordingly.

- The offset can be set in the range 0 to 15.995 MHz
- Initial setting 0.6 MHz (DJ-G17/E)

1 channel step unit	UP	DOWN
1 MHz	While pushing , rotate the dial or push .	While pushing , rotate the dial or push .

**Completion** Push or .

Push plus to enter Tone Setting Mode; push plus to enter Channel Step Setting Mode.



When either - or + is displayed, while pushing , push to display the offset frequency.

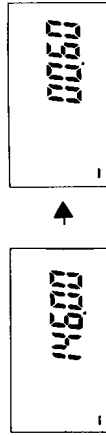

### OFF BAND

When an offset frequency results in an out-of-band transmit frequency, transmission is not possible, and the following display appears.

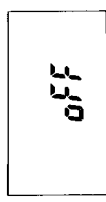

## 7-5 TONE ENCODER AND TONE FREQUENCY

When the tone encoder is set, a subaudible tone is superimposed over your transmit signal. When the optional tone squelch unit (EJ-16U) is installed, refer to page 54.

### TONE ENCODER SETUP

#### 1. Select Tone Encoder Mode

While pushing **[F]**, push **[TONE]**

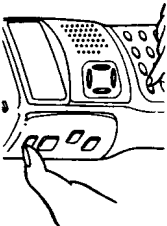

T appears and a tone frequency appear.  
(Default is 88.5 Hz)

(Unit: Hz)  
**88.5**  
 T

#### 2. Set a tone frequency

While the tone frequency is displayed, rotate the dial or push the **[MR]** / **[STEP]** keys to select one of 39 different tone frequencies.

67.0	69.3	71.9	74.4	77.0	79.7
82.5	85.4	88.5	91.5	94.8	97.4
100.0	103.5	107.2	110.9	114.8	118.8
123.0	127.3	131.8	136.5	141.3	146.2
151.4	156.7	162.2	167.9	173.8	179.9
186.2	192.8	203.5	210.7	218.1	225.7
233.6	241.8	250.3			

Table of available tone frequencies  
(Unit: Hz)

Setting Push **[MW]** / **[VZ]** or **[PTT]**

Push **[F]** and **[OFFSET]** to enter Offset Setting Mode, push **[F]** and **[STEP]** to enter Channel Step Setting Mode.

#### 3. Cancel tone setting

While pushing **[F]**, push **[TONE]**. T disappears and tone setting is cancelled. When the optional unit is installed, repeat this operation until T disappears.



While T is displayed, push **[F]** and **[TONE]** to display the currently set tone frequency.

**145000**

**→**

**88.5**  
 T

## 7-6 REVERSE FUNCTION

When you are not using a repeater and you want to see if the other party can communicate with you or not, use the Reverse Function to exchange the transmit and receive frequencies.

### RECEIVING IN REVERSE MODE

While pushing **[F]**, push **[REV]** **[3]**

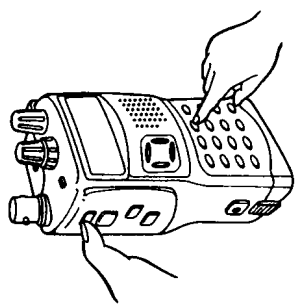

Eg. offset frequency is 0.6 MHz.

**145000**  
 -T

↔  
 Reverse

**145400**  
 +T

The transmit and receive frequencies are exchanged and the offset direction is reversed.

**To cancel** Repeat the above step to cancel the reverse function and return to the previous state.

**Note:** When an offset direction is not set or when the reverse function results in an out-of-band frequency, an invalid operation beep sounds and operation is not allowed.

## 7-7 SPLIT FUNCTION

The Split Function allows you to receive at a VFO frequency, and transmit at a memory frequency. It can only be used in VFO Mode.

### COMMUNICATING IN SPLIT MODE

**Note:** Works in the main band only.

- ① Push **[MW]** / **[VZ]** to select VFO Mode.
- ② While pushing **[F]**, push **[SPLIT]**.

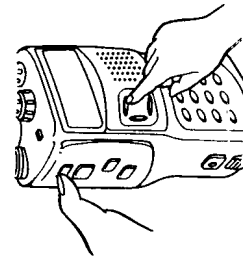

Receiving

**145000**

Transmitting

**145300**  
 L  
 M  
 10

3 ▼s appear, and Split Mode is selected.

While transmitting Memory Mode is selected.

**To cancel** Push **[MW]** / **[VZ]** or repeat the above steps to cancel Split Mode operation and return to the previous state.

## CROSSBAND TRANSMITTING

Crossband transmitting is possible when the main band frequency is programmed into memory and Split Mode operation is selected on the sub band.

- 1 Push  $\langle \text{VFO} \rangle$  to select VFO Mode.
- 2 While pushing  $\text{[F]}$ , push  $\langle \text{SUB BAND} \rangle$ .  
The main band and sub band are changed.
- 3 While pushing  $\text{[F]}$ , push  $\langle \text{SPLIT} \rangle$ .  
3  $\blacktriangledown$ 's appear and Split Mode is selected.  
While transmitting, Memory Mode is selected.

To cancel Push  $\langle \text{VFO} \rangle$  or repeat the above steps to return to the previous display.

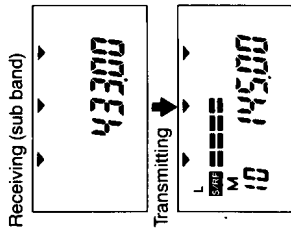

## RECEIVING IN AM MODE

Normal receiving and transmitting is carried out in FM Mode. However, AM receiving can be selected.

- 1 Push  $\langle \text{VFO} \rangle$  to select VFO Mode.
- 2 While pushing  $\text{[F]}$ , push LOW PTT (TONE BURST).  
[A] appears and AM receive Mode is selected.

Transmission is not possible by pushing  $\text{[PTT]}$ , and "OFF" is displayed.

To cancel Repeat the above steps to return to FM mode.

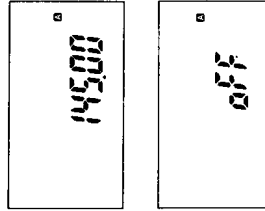

## SWITCHING BETWEEN LOW PTT KEY AND TONE BURST KEY FUNCTIONS

- 1 While pushing  $\text{[F]}$ , push  $\langle \text{KL} \rangle$ .  
[KL] appears and the Key Lock Function is activated.
- 2 Press and hold  $\text{[F]}$ , and push  $\langle \text{SPLIT} \rangle$ .

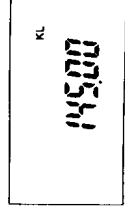

- 2 While pushing  $\text{[F]}$ , push  $\langle \text{SPLIT} \rangle$ .
- 3 While pushing  $\text{[F]}$ , push  $\langle \text{REV} \rangle$ .
- 4 While pushing  $\text{[F]}$ , push  $\langle \text{SPLIT} \rangle$ .
- 5 A beep sounds to indicate that the LOW power output and TONE BURST output have been switched.

Tone burst output

b-on

LOW power output

b-off



## NOTES REGARDING SPLIT MODE OPERATION

- The following operations are not allowed and will result in an invalid operation beep when attempted.  $\langle \text{CALL BAND} \rangle$ ,  $\text{[F]}$  plus  $\langle \text{CALL BAND} \rangle$ ,  $\text{[F]}$  plus  $\langle \text{SEARCH} \rangle$ .
- When in Memory Mode, the transmit frequency will be shifted if an offset direction is set.

## SPLIT REVERSE

When the reverse operation is performed in Split Mode, reception is on the memory frequency and transmission on the VFO frequency.

In Split Mode, while pushing  $\text{[F]}$ , push  $\langle \text{REV} \rangle$ .

Split Reverse Mode and Memory Mode are selected.

When transmitting, VFO Mode is selected.

When an offset direction is set, the transmit frequency is offset.

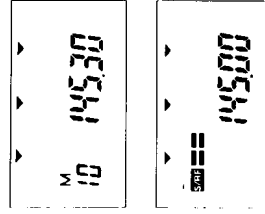



To cancel Repeat the above step to select Split Mode.  
Push  $\langle \text{VFO} \rangle$  to cancel Split Mode and select Memory Mode.

## 7-8 DISPLAY LAMP

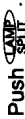
### LIGHT THE LAMP FOR 5 SECONDS

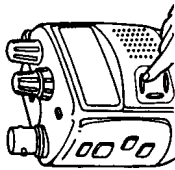
Push .





The lamp lights for 5 seconds; push  again before 5 seconds elapses to turn the lamp off.

The lamp will remain on while operating any switches or controls, and will switch off 5 seconds after the last key operation.

### CONTINUOUS LIGHTING

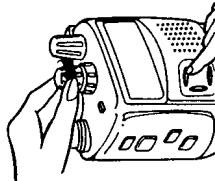
While pushing , turn power on for continuous display lighting.



Push  while the display lamp is on to turn it off; push LAMP a second time to turn it back on continuously.

Turning the power off and on will not change back to 5 seconds lighting.

To cancel While continuous lighting is activated: while pushing , turn the power on to turn the display to 5 seconds lighting mode.

Push  to turn the display lamp on for 5 seconds

## 7-9 KEY LOCK AND PTT LOCK



### LOCKING KEYS

This function conveniently locks keys to prevent accidental frequency changes, function access, and transmission.

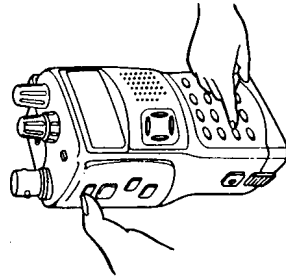
While pushing , push .



Each push of the key changes the setting as illustrated on the following page.

During key lock (KL appears) only   and  are functional. The dial is also locked.

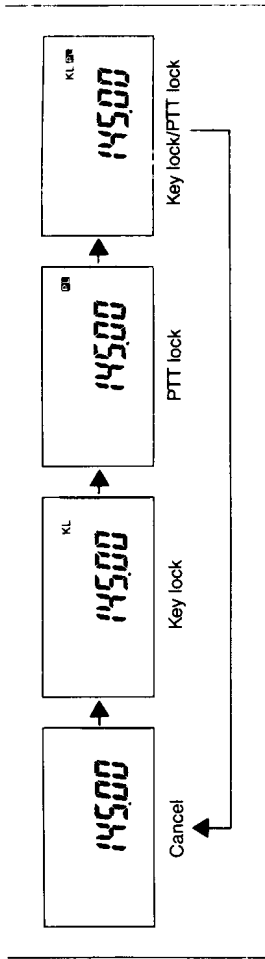

During PTT lock (PL appears) transmission is not possible.



## 7-10 AUTO POWER OFF

The Auto Power Off Function automatically turns the transceiver power off if no switches or controls are operated, or no signal is received for 30 minutes. This function protects against battery drainage when you forget to turn the power off.

### SETTING AUTO POWER OFF

While pushing , push .

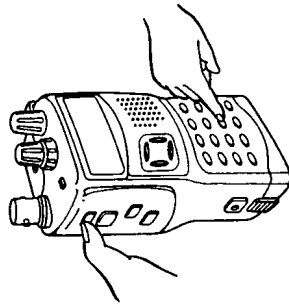

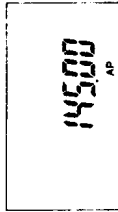

AP appears and the Auto Power Off function is set.



To cancel Repeat the above operation (AP disappears).

While AP appears, if no signal is received and no operations are performed for 30 minutes, a melody plays. At the end of the melody, the transceiver power is automatically turned off. However, a small amount of current continues to flow in some of the solid-state components in the transceiver. As soon as possible turn the power off properly by rotating the  dial counterclockwise.

To turn the power on after the power has been turned off with the Auto Power Off function, rotate  counterclockwise until a click is heard, then rotate  clockwise to turn the power back on.

## 7-11 BATTERY INDICATOR

When the battery is low, BATT appears in the display.

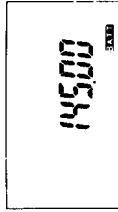

## 7-12 BATTERY SAVE FUNCTION

The Battery Save Function helps conserve battery power. When the Battery Save Function is on and no operation is performed and no signal is received for 5 seconds, the receive circuit automatically goes into a repeating cycle of on (200 ms)/off (400 ms). The default setting is Battery Save on.

### TURNING THE BATTERY SAVE FUNCTION OFF

While pushing **[F]**, push **[MONI]**

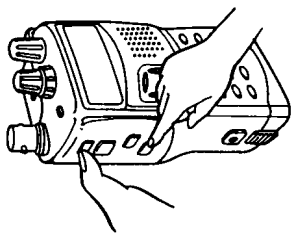

S appears and the Battery Save Function is turned off.

Battery Save on

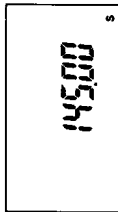

off

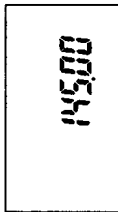

To reset Repeat the above operation to turn the Battery Save Function back on.

## 7-13 BEEP TONES

Beep tones can be turned off if desired.

### TURNING BEEP TONES OFF

While pushing **[MONI]**, turn the power on.

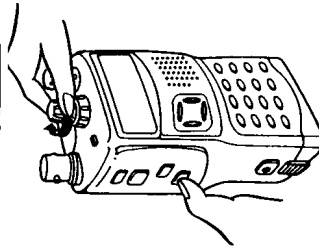

No beep tone sounds when keys are pushed.

DSQ receive alarm tones and the Auto Power Off melody are also turned off. However, DTMF code transmit tones cannot be turned off.

To reset Repeat the above operation to turn the beep tones back on.

## 7-14 DSQ (DTMF SQUELCH)

The DSQ (DTMF Squelch) Function sends a DSQ code (DTMF code) before voice transmission. If another transmitter has the same code set, its squelch opens and communication is possible. This function is very convenient for communicating with specific station(s) only. Moreover, when you receive a DSQ call, the display indicates that you are being called.

There are three DSQ modes:

### (1) Code Squelch Mode

A three-digit code is sent and opens the squelch of stations having that code only. This is similar to tone squelch operation.

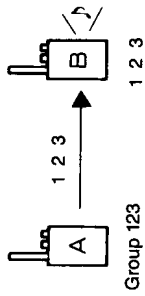

### (2) Group Pager Mode

You can call a group of stations using the group code. An individual code is also sent so that the receiving stations know who called them.

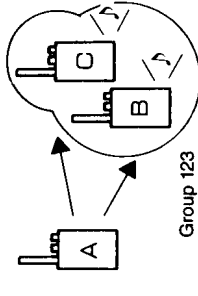

### (3) Private Pager Mode

This mode is for calling a specific station only.

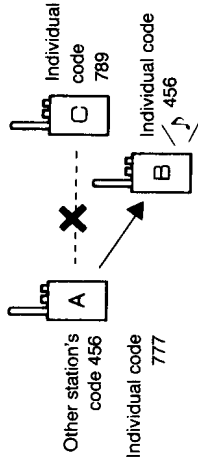

DSQ codes

DSQ transmit/receive codes are all three-digit codes as indicated in the table below.

Code type	Description	Memory
Group code	There are eight codes available for common communication within groups. These codes are required for Group Pager Mode communications. These codes can be used in combination with code squelch operation.	M1 ~ M8
Individual code	Specific individual private code. This code is necessary for receiving Private Pager calls.	MP
Other station code	This is an individual code for private calling of a specific station.	MY

Note: In Channel Scope Mode, DSQ (DTMF Squelch) is temporarily cancelled.

## SETTING A DSQ CODE

Before transmitting/receiving in DSQ Mode, you must first set DSQ codes.

### 1. Entering setting Mode

While pushing **[F]**, push **DSQ SET** .

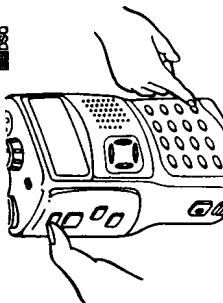

A DSQ code is displayed (the default is 000).



### 2. Selecting a code type

Rotate the dial to select a desired code type as shown below.

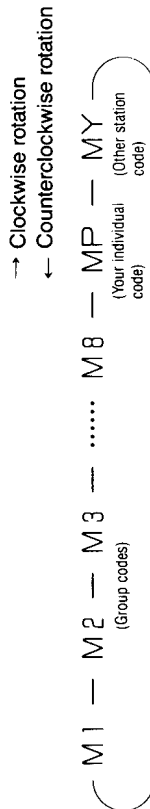

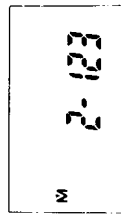

### 3. Inputting the three digits of the code

Use the keypad to input the corresponding code digits.  
▼ appears above M while inputting the digits.



### 4. Setting the code

Push **MRV** , **[PTT]** or while pushing **[F]**, push **DSQ SET**  to set the desired code.

## IF YOU MAKE A MISTAKE WHILE INPUTTING

While pushing **[F]**, push **MRV** . The code becomes 000, and you can begin inputting from the beginning again.

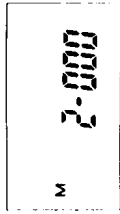

## About M

While group codes M1 to M8 are indicated, ▼ appears above M to indicate that group calls can be received with that particular code.

When DSQ code operation is set, while pushing **[F]**, push **MRV**  to toggle ▼ on and off.

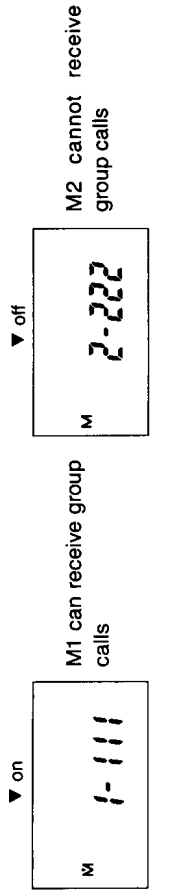



## SETTING DSQ MODE

Choose 1 of the 3 DSQ Modes to communicate with.

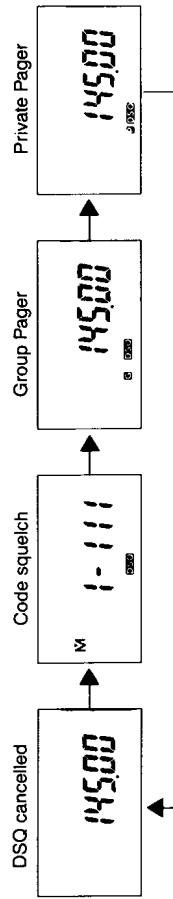
① Each push of **DSQ SET**  changes the DSQ Mode.



② When DSQ only is indicated, a group code appears.

Use the dial or **MRV**  / **MRV**  keys to select a group code M1 to M8.

③ To communicate in Code Squelch Mode, while a group code is displayed, push **MRV**  and the display returns to frequency indication. In addition, pushing **[PTT]** returns the display to frequency display and transmits the code as well.

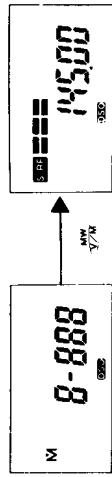



## COMMUNICATING IN CODE SQUELCH MODE

### 1. Before transmitting

1. Refer to page 43 to input a group code.
2. Push  several times.

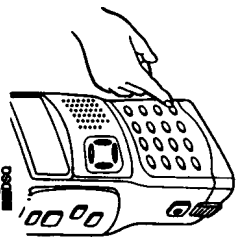

DSQ and a code appear.

3. Use the dial and  /  keys to select a transmit and receive code.

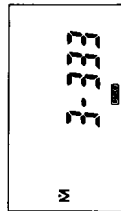



4. Push  to return the display to frequency display.

### 2. Transmitting

Push  and the last displayed group code is transmitted. A three-tone beep sounds.

### 3. Receiving

When the received code matches the last displayed group code, the squelch opens and you can hear the transmission.

- An alarm beep sounds two times.
  - DSQ flashes.
- Push  or  to stop the flashing.

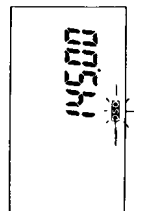

Beep Beep

 When the last displayed code is your code or another station's code, the code type will automatically change to M1.

## COMMUNICATING IN GROUP PAGER MODE



### 1. Before transmitting

1. Refer to page 43 to set a group code and your own station code.

2. Push  several times.



DSQ and a code appear.

3. Use the dial or  /  keys to select a transmit and receive code.



4. Push  again.  appears.

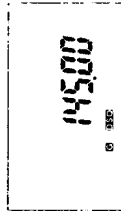

### 2. Transmitting

Push  to transmit a seven-digit code as shown at right.

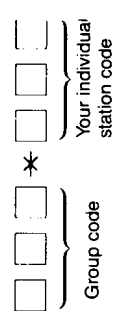

### 3. Receiving

When you receive a code which matches one of your set group codes (M1 to M8), the squelch opens and you can hear the transmission.

- The alarm sounds several times.
- The group code appears in the display.
-  flashes.

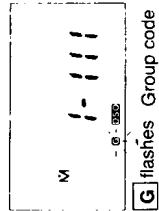

 flashes Group code

When a code matching your individual code is received, the transceiver automatically goes into Private Pager Mode.

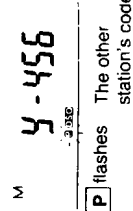

 flashes The other station's code

- Push any key to stop the alarm.

- While **[G]** or **[P]** flashes and a code is displayed, push **[MW]** or transmit to return to the previous display.

#### 4. Communicating

While a matching code is displayed, push **[PTT]**.  
The displayed code is sent and you can answerback.

### COMMUNICATING IN PRIVATE PAGER MODE

#### 1. Before transmitting

① Refer to page 43 to set other station code and your own individual code.

② Push **[DSQ SET]** several times until **[P]** DSQ appears.



#### 2. Transmitting

Push **[PTT]** and a code as at right is transmitted.

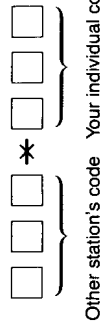

#### 3. Receiving

Receiving is the same as in Group Pager Mode. (page 46)

When a received code matches one of your set group codes, the transceiver automatically enters Group Pager Mode (your individual code has priority over group codes).

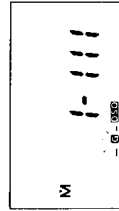

#### 4. Communicating

While a received code appears in the display, push **[PTT]**.

### TRANSMITTING DTMF CODES MANUALLY

Even if DSQ Mode is not set, you can transmit DTMF codes one at a time, manually.

While pushing **[PTT]**, push the digit keys on the keypad.

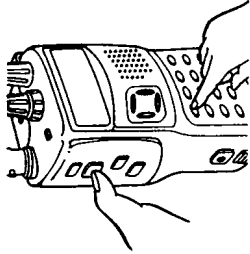

The keys must be pushed within 1.5 seconds of each other to open the DSQ of the other station.



### DSQ RECEIVE ERROR DISPLAY

In Group and Private Pager Mode, if the other station's code is not received properly during receive operation, E appears in the display to indicate an error.

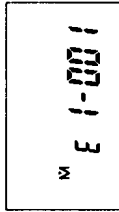

In Private Pager Mode, the previously received station code is displayed.

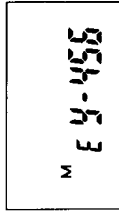

### NOTES REGARDING DSQ RECEPTION

- When DSQ codes are set, if ▼ is not indicated above M, group codes cannot be received (see page 44).
- During DSQ reception, after the squelch is opened, communication is still possible if the signal is interrupted for less than 1.5 seconds.
- When no signal is being received adjust the SQL control so that the **[S/RF]** meter does not appear.
- Push and hold **[MONI]** to temporarily open the squelch without affecting the SQL control setting.
- When the Battery Save Function is on, it can be difficult to receive DSQ codes. We recommend turning the Battery Save Function off while using DSQ codes.

## COMMUNICATING WITH DSQ CODES THROUGH A REPEATER

In normal DSQ code operation, a DSQ code is sent about 450 ms after pushing **PTT**. When operating through a repeater, the repeater relays the code after it is sent. Therefore, it is necessary to slow the transmit time down to about 750 ms. when using a repeater.

- ① While pushing **F**, push **WAIT** 

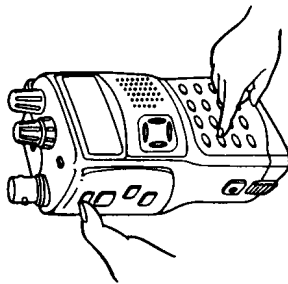

Each push of the key changes the transmit time.

Normal

d-450

Time while using DSQ Mode through a repeater

d-750

- ② Push  or **PTT** to return to the previously displayed frequency.

## 7-15 DIAL FUNCTION

This function automatically sends pre-programmed DTMF codes. This transceiver has 5 DIAL memories available.

### PROGRAMMING A CODE INTO MEMORY

#### 1. Entering setting mode

While pushing **F**, push **DIAL M** 

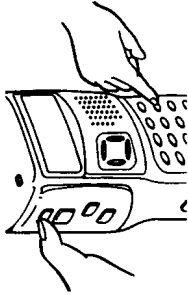

DIAL and a DIAL Memory No. appear and Code Input Mode is selected.

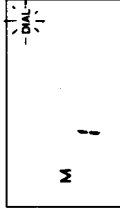

#### 2. Selecting a memory No.

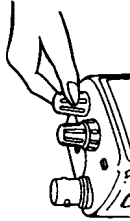

Rotate the dial to select one of the 5 memories.

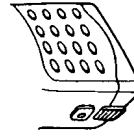

#### 3. Inputting a code

Use the keypad to input the code from the leftmost digit to the right.





 is displayed as **H**.  
 is displayed as **H**.

Inputting a code

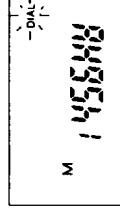
The last 5 digits of the code are displayed. Digits to the left were input before digits to the right. Up to 15 digits can be input.



#### 4. Setting a code

Push , **PTT**, or **F** and **DIAL M**  to set the code and complete the programming.

Complete the programming while the memory No. is selected. (DIAL appears.) When you don't want to transmit the DIAL memory, choose a memory No. in which no code has been input (DIAL does not appear).

## CHANGING A PROGRAMMED CODE

1) While pushing **[F]**, rotate the dial or use the Up ▲/Down ▼ keys to scroll the code display.

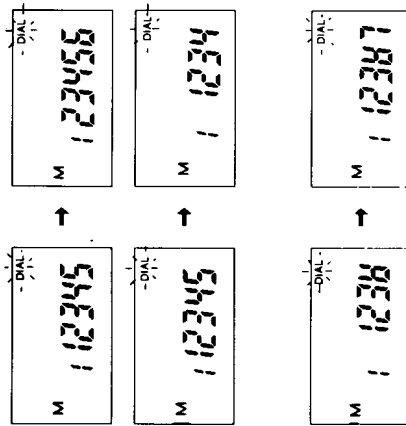
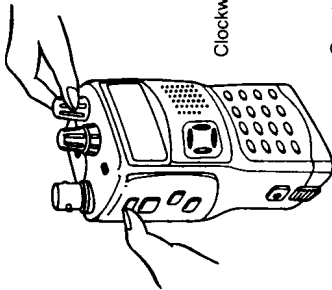

Clockwise rotation

Counterclockwise rotation

2) Input a new code.

e.g Change 123 # 354 to 123 # 754

## TRANSMITTING A DIAL MEMORY CODE

1. Select a memory No.

- 1) While pushing **[F]**, push **[B]** or **[PTT]**.
- 2) Select a memory No. using the dial.
- 3) Push **[MW]** or **[V/B]**.  
DIAL appears.

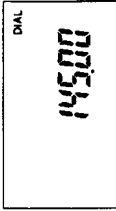

2. Transmitting the code

While pushing **[PTT]**, push **[F]** to transmit the selected memory code.

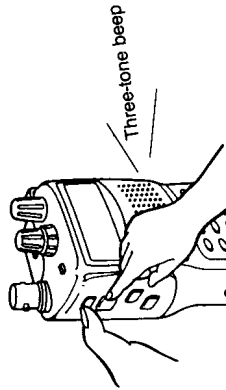

**Note:** When DIAL does not appear in the display, a code cannot be sent using the above operation.

## ! IF YOU MAKE A MISTAKE WHILE INPUTTING

While pushing **[F]**, push **[C]** to erase the displayed code.  
Then, reinput the code from the beginning.

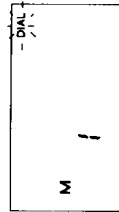

## ! INPUTTING A PAUSE

Inputting a pause into a code provides a 1 second delay between the transmitted digits of the code.  
During input, while pushing **[F]**, push **[0]**. '-' appears and a pause is inserted into the code.

(A pause can be put into any position within the 15 digits of a code.)

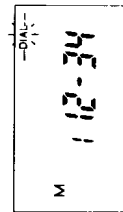

▲ There is a 1 second pause between output of the 2 and 3 digits of the code.

## 7-16 RESETTING THE CPU

Resetting the CPU returns all programmed memory contents to their factory-set default values.

### RESETTING

While pushing **[F]**, turn the transceiver power on.

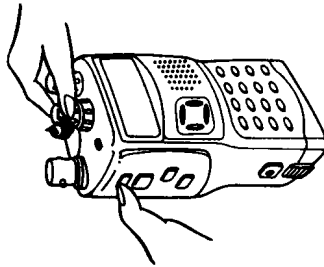

Continue pushing **[F]** until all segments of the function display appear, then release **[F]** to return to normal operation.

(everything appears on LCD)

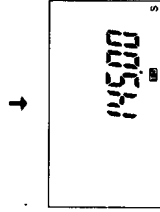

## 8-1 TONE SQUELCH

The optional Tone Squelch Unit must be installed in order to use the Tone Squelch Function. During tone squelch operation, when a signal is received that contains the subaudible tone set for reception, the squelch opens and you can hear the signal.

Normal tone squelch operation uses the same subaudible tones for both transmit and receive. However, memory channels 70 to 79 can be used to set different subaudible tones for transmit and receive.

### SETTING THE TONE SQUELCH FUNCTION

#### 1. Selecting Tone Squelch Mode

While pushing **[F]**, push **[TONE]** several times.

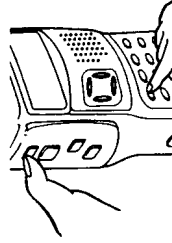

TSQ and the currently set tone frequency appear.

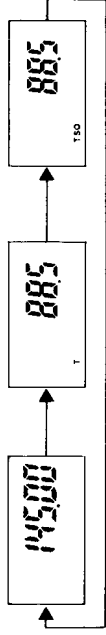

#### 2. Setting a tone frequency

While a tone frequency is displayed, use either the dial or **[MR]** / **[MRY]** keys to select 1 of 39 possible tone frequencies.

(See page 35 for a list of possible tone frequencies.)

To finish Push **[M]** or **[PTT]** to return to the previous display.

#### 3. Cancelling the Tone Squelch Function

When TSQ appears, while pushing **[F]**, push **[TONE]**.



### TRANSMITTING/RECEIVING WHILE TSQ APPEARS

Transmit...the selected subaudible tone is superimposed over your transmission.

Receive... when a signal containing a matching tone is received, the squelch opens and you can receive the transmission.

- Push and hold **[MONI]** to temporarily open the squelch.
- When communicating through a repeater, do not use the Tone Squelch Function. Depending on the repeater, subaudible tones may cause your communication to be interrupted.
- The tone squelch setting is also stored when programmed into one of memory channels 0 to 69. Channels 70 to 79 can store different tone frequencies in transmit and receive. See page 55 for details.

Factory default settings after resetting the CPU

	T	DJ-G1	E
VFO Frequency	145.00 MHz		
Channel Step	5 kHz	12.5 kHz	
Shift	None		
Offset	0.6 MHz		
CTCSS Setting	None		
Tone Freq.	88.5 Hz		
Memory Channel Data	None		
Memory No.	1		
Call Freq.	145.00 MHz		
Scan Condition	Timer Scan		
Program Scan Edge Freq.	145.00 MHz		
Battery Save	ON		
DSQ Setting	None		
DSQ Code	000		
DIAL Memory	None		
Auto Power Off (APO)	OFF		

Problem	Possible cause	Solution	Page
Power is on but nothing appears in the display.	a. Battery case is not connected properly. b. + and - polarities of the batteries are reversed. c. Batteries are flat.	a. Make sure the battery case and connections are as they should be. b. Make the polarities of the batteries are correct. c. Exchange dry cell batteries with new ones; charge Ni-Cd batteries.	3
No sound comes from the speaker. Receiving is not possible.	a. <b>[VOL]</b> is rotated too far counterclockwise. b. The squelch is closed. c. Tone Squelch Function is set. d. DSQL Function is set. e. <b>[PTT]</b> is pushed and transmit condition is selected.	a. Adjust <b>[VOL]</b> to suitable level. b. Rotate <b>[SQL]</b> counterclockwise. c. Cancel tone squelch operation. d. Cancel DSQL operation. e. Release <b>[PTT]</b> .	11 11 35 42 12
Scanning does not work.	Squelch is open.	Set <b>[SQL]</b> to the point where audio noise is just muted when receiving no signal.	11
Frequency cannot be changed.	a. C appears in the display. b. The frequency lock (KL) function is activated.	a. Select VFO Mode. b. Cancel the frequency lock function.	18 39
While transmitting, the display flashes and all indications disappear.	Batteries are flat.	Replace or charge the batteries.	3
Transmitting is not possible.	a. Batteries are flat. b. The PTT Lock (PL) Function is activated.	a. Replace or charge the batteries. b. Cancel the PTT lock function.	3 39

## SETTING DIFFERENT TRANSMIT/RECEIVE TONE FREQUENCIES

### 1. Setting a transmit tone frequency

- Store operating frequency, and offset into one of channels 70 to 79.
- In Memory Mode, call up the above-programmed channel.
- While pushing **[F]**, push **[TONE]** several times so that TSO appears.
- Use the dial or **[MR]** / **[M/R]** keys to select a transmit tone frequency.
- Proceed with steps ⑥ and ⑦ below (even if you are setting the same tone frequency for receiving).

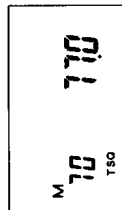

### 2. Setting a receive tone frequency

- While pushing **[F]**, push **[TONE]** to indicate that the receive tone frequency is different from the transmit tone frequency.
- Use the dial or **[MR]** / **[M/R]** keys to select a receive tone frequency.

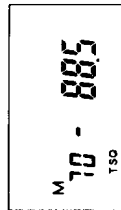

**Note:** If you stored a tone frequency from VFO to memory in step ①, that tone frequency has been programmed as a transmit tone only, and the receive tone must yet be programmed (steps ⑥ ⑦) even if the receiving tone is to be same as the transmit tone. Push **[V/M]** or **[PTT]** to return to the previous display. When a tone frequency is programmed into a memory, the set contents are memorized.

## INSTALLING THE TONE SQUELCH UNIT

Make sure the transceiver power is off.

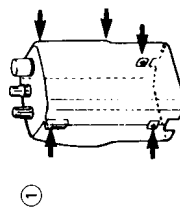

① Unscrew the 5 indicated screws to remove the battery case.

② Separate the front panel from the back panel as indicated.

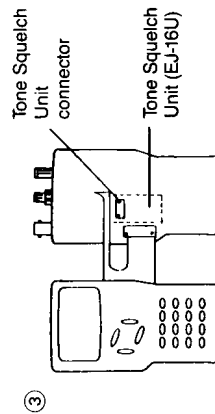
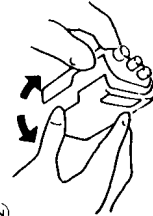

③ Attach the Tone Squelch Unit to the tone squelch connector.

④ Place the front and back panels back together, then secure them with the 5 screws removed in step 1.

## 10. OPTIONS

- EDH-14 Drycell battery case ("AA" cell x 6 pcs: 9V DC) Regular size
- EBP-30N Ni-Cd battery pack (7.2V 700 mA) Regular size
- EBP-31N Ni-Cd battery pack (7.2V 1200 mA) Long size
- EBP-32N Ni-Cd battery pack (12.0V 700 mA) Long size
- EDC-55 Charger (120V AC)
- EDC-56 Charger (220V AC)
- EDC-52 Quick charger (120V AC)
- EDC-53 Quick charger (220V AC)
- ESC-23 Soft case (Regular size)
- ESC-24 Soft case (Long size)
- EJ-16U Tone squelch unit
- EMS-8 Remote control speaker-microphone
- EME-15 Tie-pin microphone with VOX
- EDC-36 Car cigarette-lighter cable with filter

# 11. Ni-Cd BATTERY PACK

## NOTES ON THE Ni-Cd BATTERY PACK (EBP-30N, EBP-31N, or EBP-32N)

### EBP-30N, EBP-31N, EBP-32N

- The battery pack is not charged when shipped. It must be charged before using.
- Charging should be conducted in the temperature range of 0°C to 45°C, as incomplete charging or deterioration of battery performance may occur if charged outside this range.
- Do not modify, dismantle, incinerate or immerse the battery pack in water as this may be dangerous. Be careful not to drop the battery pack or subject it to any severe shocks.
- Never short-circuit the battery pack terminals, as this may cause damage to the equipment or lead to heating of the battery which may cause burns.
- Unnecessarily prolonged charging (overcharging) may result in deterioration of battery performance.
- The battery pack should be stored in a dry place with a temperature range of -20°C to +45°C. Temperatures outside this range or extremely high levels of humidity may lead to leaking of the battery liquid or resting of the metal components of the batteries.
- Normally the battery pack can be charged up to 300 times. However, the battery pack can be considered to be exhausted if the period of use drops off markedly despite being charged for the aforementioned time. When this happens a new pack should be used.

**ATTENTION:** The battery is recyclable. At the end of its useful life, under various state and local laws, it may be illegal to dispose of this battery into the municipal waste stream. Check with your local solid waste officials for details in your area for recycling options or proper disposal.



**Ni-Cd**

## CHARGING with EDC-55 or EDC-56 (NORMAL CHARGER)

- Mount the Ni-Cd battery pack in the charger. The red lamp will light up and charging will start.
- See table 2 for charging time. Dismount the battery pack from the charger after the charging.

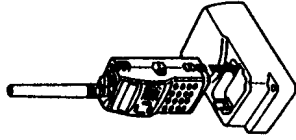

## CHARGING with EDC-52 or EDC-53 (QUICK CHARGER)

- Mount the Ni-Cd battery pack in the charger. The red lamp will light up and charging will start.
- When the battery pack is mounted correctly, the red lamp will light up and quick charging will start. When quick charging is completed, the red lamp will go off/the green lamp will light up. The charge rate will be then reduced to a weak supplementary charge rate to protect the battery pack from overcharging.

## Specifications:

table 1

	EBP-30N	EBP-31N	EBP-32N
<b>BATTERY CAPACITY</b>	700mAh	1200mAh	700mAh
<b>OUTPUT VOLTAGE</b>	7.2V	7.2V	12V

## CHARGING TIMES and CHARGERS

table 2

	EBP-30N	EBP-31N	EBP-32N
<b>EDC-55 (for 120V) EDC-56 (for 220V)</b>	Approx. 14 hours	Approx. 24 hours	Approx. 14 hours
<b>EDC-52 (for 120V) EDC-53 (for 220V)</b>	Approx. 1 hour	Approx. 1.8 hours	Approx. 1.8 hours

The above times are required for completely discharged battery pack.

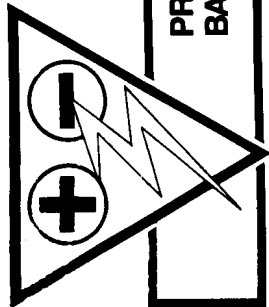

# ATTENTION!

## PREVENT SHORT-CIRCUITING OF THE Ni-Cd BATTERY PACK

Be extra cautious when carrying the Ni-Cd battery pack; short-circuiting will produce surge current flow resulting in possible fire.

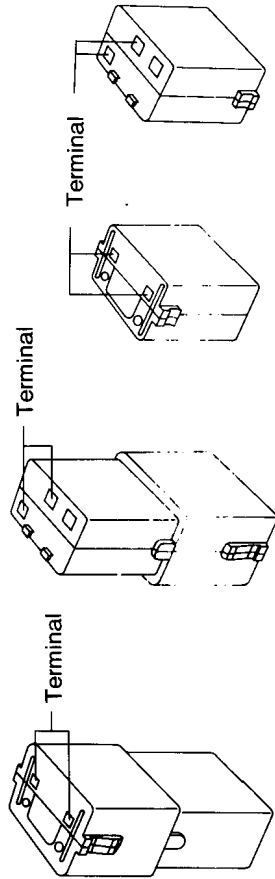

<p>DON'T carry with metals of any type, e.g. chains.</p>	<p>DON'T carry the Ni-Cd battery pack inside bags of metal plated interior.</p>	<p>DON'T place in the proximity of metals or conductives, e.g. nails, chains.</p>
<p>DO enclose inside a non-conductive enclosure (bag or handkerchief made only of non-conductive material).</p>	<p>DO protect by spreading a non-conductive sheet to place on a flat surface.</p>	

\*When carrying the battery pack, it should be kept in the bag provided.

# N O T I C E

This equipment has been tested and found to comply with the limits pursuant to Part 15 of the FCC Rules. These limits are designed to provide reasonable protection against harmful interference in a residential installation. This equipment generates, uses, and can radiate radio frequency energy, and if not installed and used in accordance with the instructions, may cause harmful interference to radio communications. However, there is no guarantee that interference will not occur in a particular installation. If this equipment does cause harmful interference to radio or television reception, which can be determined by turning the equipment off and on, the user is encouraged to try to correct the interference by one or more of the following measures.

- Reorient or relocate the receiving antenna.
- Increase the separation between the equipment and receiver.
- Connect the equipment into an outlet on a circuit different from that which the receiver is connected.
- Consult the dealer or an experienced radio/TV technician for help.