

# *Bearcat III*

## FM MONITOR RECEIVER

MODEL BC3-L, H, U, L/H, L/U, H/U

MADE IN U.S.A.

## OPERATING INSTRUCTIONS



Patent No. 3, 531, 724

  
**Electra** COMPANY



DIVISION OF MASCO CORPORATION

CUMBERLAND, INDIANA 46229

© Copyright 1973 by Electra Company

## GENERAL DESCRIPTION

The Bearcat III is a table and mobile model, single or dual band FM monitor receiver providing automatic scanning of 8 channels in one or two of the three Public Safety/Business Bands at 30-50mHz, 146-174mHz and 450-470mHz.

Its features include: provisions for one or two plug-in r-f modules; 8 plug-in crystals in any combination may be used; high speed automatic or manual scanning; channel switches to omit scanning of undesired channels; solid state Light Emitting Diode channel indicators; combination squelch and sensitivity control; front-mounted 3" x 5" speaker; external speaker jack; cables for 117Vac or 12Vdc operation;

and operation from a single telescoping or outside antenna.

The most advanced developments in solid state circuitry are incorporated in this receiver; dual-gate MOS Field Effect r-f and mixer transistors provide low noise and low cross-modulation. Single conversion into monolithic quartz crystal i-f filters reduces spurious responses and radiation and improves selectivity; linear integrated circuits provide i-f gain, detection, audio amplification and output; TTL I.C. multivibrators and gates provide scanning logic; desired channels are scanned with no time lost scanning unwanted channels.

## SPECIFICATIONS

**Size:** 9" W x 3 5/8" H x 6 1/8" D

**Weight:** 5 lbs.

**Cabinet:** Heavy duty vinyl-clad steel. Non-sliding feet.

**Power Requirements:** 117 Vac, 12 W; 13.8 Vdc, 6 W.

**Audio Output:** 3 W rms, voice (Power protected at 1.5 W on continuous tones). External speaker connector provided.

**Antenna:** Telescoping antenna (supplied). Connector provided for outside or mobile antenna

**Input Impedance:** 50-70 ohms.

**Sensitivity:** H and L bands: readable at .25 microvolt for  $\pm 5$  kHz deviation, .7 microvolt for 20 dB signal-to-noise ratio: U band slightly less.

**Channels:** Up to 8 crystal-controlled channels (in one or two bands) may be scanned automatically or selected individually or in any combination.

**Frequency Range:**

Low band \*30-50 mHz, total spread 15 mHz.

High band \*146-174 mHz, total spread 24 mHz.

UHF band 450-470 mHz, total spread 20 mHz.

(\*Factory-supplied alignment for Low band is 33-48 mHz. High band is supplied with 150-174 mHz alignment. Other alignments are available on special request.)

**Scan Rate:** Approximately 25 channels per second.

**Crystals:** Miniature plug-in type HC-25/U for easy user installation.

**Accessories Supplied:** All-band telescoping antenna / Universal mobile mounting bracket / 117 Vac power cable / 13.8 Vdc power cable (Connects to "Accessory" or "Radio" fuse block. FOR USE WITH NEGATIVE GROUND SYSTEMS ONLY).

**Front Panel Features:** Squelch control / Volume on-off control / Combined Manual-Scan Channel Select Switch / 8 channel switches / 8 Light Emitting Diode channel indicators / Forward-facing 3" x 5" speaker.

Listed by Underwriters' Laboratories, Inc.

Certified under FCC Reg. Part 15.

## INSTALLATION INSTRUCTIONS

This receiver is shipped complete with the necessary accessories for mobile or table use. As a fixed receiver in areas of fair-to-good signal strength, the telescoping whip antenna supplied, may be used on all bands.

If an outside antenna is necessary for fringe reception, you may use a 155MHz antenna on all bands, a 40MHz antenna for L and L/H models or a 460MHz antenna on U models only. External antennas should be coupled to the receiver by 50 ohm coaxial cable, such as RG-58 A/U, using the supplied automotive type connector. Suitable antennas are available at most radio dealers.

### MOBILE INSTALLATION

This receiver may be installed in any car, truck, boat, etc., having a 12 VOLT NEGATIVE GROUND SYSTEM.

In some areas it is illegal for unauthorized persons to receive police communications on a mobile receiver. The user of this radio is responsible for obtaining any necessary authorization through local agencies and Electra Company cannot be responsible for any illegal installation or usage.

1. Place the mobile mounting bracket under the dash to hold the receiver in the desired position.
2. Mark and drill two holes using a 7/64 drill bit and secure the bracket with the two No. 6 self-tapping screws.
3. Insert the two plastic "T" washers, flanges turned inward, in the desired pair of mounting holes and secure the receiver in place with the two 1/4-20 bolts and two 1/4" ID x 9/16" OD flat washers.
4. Attach the DC power cable and connect it to the "accessory" or "radio" terminal on the fuse block.
5. External mobile antennas may be used as described above. The automotive antenna may be used fully extended for L, H or L/H models. It should be reduced to approximately 18" for U models.

The noise generated by the auto electrical system and other parts of the car is sometimes a problem, particularly in areas of low signal strength. The subject of noise elimination is too lengthy to deal with adequately in this instruction book.

It is recommended for those who wish to become familiar with the subject to purchase "The Radio Amateur's Handbook" or "The Mobile Manual" published by the American Radio Relay League and sold by most electronic parts stores. It is further recommended that the vehicle be taken to a service center which specializes in VHF-UHF two way radio communications equipment for correction of a noise problem.

### OPERATION

1. With the power cable and antenna properly connected, turn the receiver ON by rotating the "VOLUME" control clockwise.
2. Place the 8 channel switches in the up (ON) position.
3. Set the "MANUAL-SCAN" switch on "MANUAL".
4. Adjust the "SQUELCH" control clockwise until the rushing noise is heard. Then adjust the "SQUELCH" control counterclockwise until the rushing noise disappears.
5. Press the "MANUAL-SCAN" switch downward and continue to step through all channels. If the noise should "break the squelch" on any channel, adjust the squelch control counterclockwise again slightly to quiet the receiver. THIS MUST BE DONE BETWEEN STATION TRANSMISSIONS.
6. The "MANUAL-SCAN" switch may now be used to select and monitor any desired channel.
7. To sample all channels automatically, return the "MANUAL-SCAN" switch to "SCAN". Any channel may be omitted as desired by moving the individual channel switch downward (off).

## CRYSTAL INSTALLATION

### DISCONNECT POWER BEFORE REMOVING CABINET LEAVE POWER OFF WHILE INSTALLING CRYSTALS

To remove the cabinet, first remove the screw at the bottom rear edge. Push the rear panel forward through the cabinet. The components and crystal sockets are in full view and easily accessible.

The three crystal pin sockets at the front are for channel No. 1. The second row of 3 is for channel 2 etc. Each crystal will be installed between the center row and one outside row. The outside rows connect to the r-f module nearest them on the opposite side of the board. Only one outside row will be used when only one r-f module is used. A total of eight crystals may be used. They may be installed in any order and in either band as long as each crystal frequency is proper for the particular module to which it is connected.

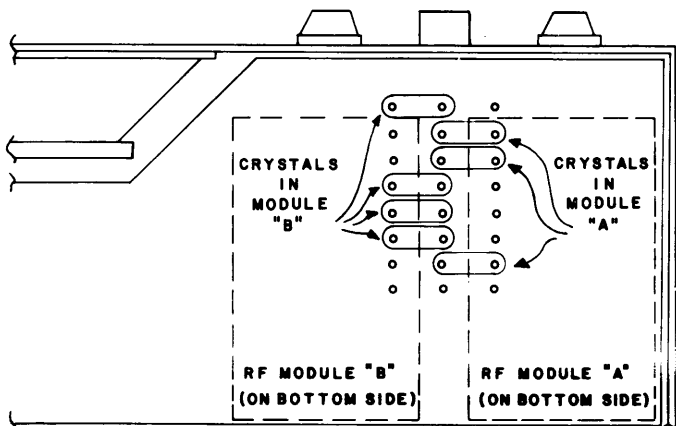

L, H or U modules may be in either position.

Figure 1

Remove the crystal by a gentle pull upward. Insert the crystal by aligning the pins with the sockets and pushing straight down. **DO NOT BEND THE SOCKETS. THESE MINIATURE SOCKETS ARE MADE OF SPRING BRONZE AND WILL BREAK OFF IF BENT EXCESSIVELY.**

**NOTE:** Do not install two crystals of the same frequency.

Rigid quality standards are applied to crystals furnished by Electra Company to assure full performance, therefore our warranty does not include correcting poor operation caused by crystals from other sources.

Unless ordered otherwise the "U" alignment spread is 450mHz to 470mHz, the "H" 150mHz to 174mHz, and the "L" 33mHz to 48mHz. New frequencies may be added within these spreads.

### CRYSTAL FORMULAS

"H" -  $\frac{\text{Received frequency} - 10.80 \text{ mHz}}{3} = \text{crystal frequency.}$

Example:  $\frac{155.01 \text{ mHz} - 10.80 \text{ mHz}}{3} = 48.07000 \text{ mHz}$

"L" -  $\text{Received frequency} + 10.80 \text{ mHz} = \text{crystal frequency.}$

Example:  $35.80 \text{ mHz} + 10.80 \text{ mHz} = 46.60000 \text{ mHz}$

"U" -  $\frac{\text{Received frequency} - 10.80 \text{ mHz}}{9} = \text{crystal frequency.}$

Example:  $\frac{453.250 \text{ mHz} - 10.80 \text{ mHz}}{9} = 49.16111 \text{ mHz}$

## USER HINTS

Radio equipment usually operates in an environment of man-made electro-magnetic noise which radiates from power lines, fluorescent lights, motors, appliances, ignition systems, etc. Modern radios are designed to minimize interference from such sources but operation may be affected under conditions of unusually strong noise.

Distant weak, "skip" or noise signals may be received by this receiver because of its high sensitivity. Whenever such conditions interrupt scanning or whenever a very busy channel prevents reception of other desired signals, the affected channel may be bypassed by means of its individual panel switch.

The squelch control functions in the normal manner and, in addition, as it is rotated counterclockwise farther, it becomes a sensitivity control. By careful setting, it can accept weak signals or can be adjusted to receive only medium or strong signals. Interference from weak signals on the same channel may be reduced in this manner.

In cases of strong interfering noise or signals it may be desirable to reduce the length of the antenna to reduce noise pickup below a critical level. This may be very effective in medium and strong signal areas.

Single-channel operation may be obtained as described under Operating Instructions. It may also be accomplished with the "MANUAL-SCAN" switch in either position by locking out all but the desired channel. This assures that the radio will always be on that channel even when turned OFF and ON. Continuous-carrier signals such as the ESSA weather broadcasts on 162.55mHz, which are available in many areas, may be received when desired by use of the individual channel switches.

In mobile service the commonly encountered poor reception conditions are signal fading, nearby faulty ignition systems, power lines and proximity to strong signals. Careful setting of the squelch control will minimize these conditions.

When moving or shipping the radio, remove the telescoping antenna to avoid damage to it or to the internal circuit assemblies.

## RADIO SERVICES

Local Government	Special Emergency	Police
Highway Maintenance	-Hospitals	Fire
Forestry-Conservation	-Ambulances	Press
Motion Pictures	-Physicians	Business
Special Industrial	-Disaster Relief	Railroad
Telephone Maintenance	-School Busses	Taxicab
Automobile Emergency	Power	Marine
Public Mobile Radio	Petroleum	Manufacturers
Mobile Telephones	Forest Products	Motor Carrier
		Rural Radio

## ALIGNMENT

### I-F SECTION

Alignment of the I-F system consists of optimizing the input and output networks and balancing the detector output. The bandpass and center frequency are established by quartz crystal filters and "peaking" the coils can result in bandpass ripple or poor sensitivity. Field alignment should not be necessary but the procedure is given for general information.

#### EQUIPMENT NEEDED

Oscilloscope

Sweep generator with 10.79, 10.80  
and 10.81MHz markers

1. Connect sweep generator to TP-1 through a lpf capacitor.
2. Connect oscilloscope to TP-2.
3. Maintain output of 10.8MHz sweep generator at a low level to prevent distortion from overloading.
4. Adjust T1 and T2 for maximum output, and minimum ripple. See Figure 2.

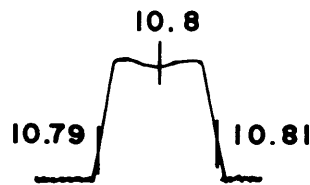

Figure 2

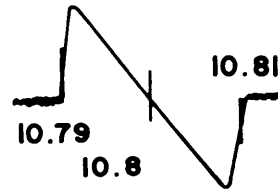

Figure 3

5. Connect scope to pin TP-2 and adjust T3 so that 10.8MHz is in center of discriminator curve and for best linearity. See Figure 3.

**ALTERNATE METHOD:** I-F alignment may be checked using a Measurements Model 800 Generator or equivalent tuned to an operating frequency and swept  $\pm 25$ kc. Markers are not essential since center frequency is determined by the filter.

### R-F SECTION

DO NOT ATTEMPT ALIGNMENT OR "PEAKING" OF R-F MODULES.

The R-F alignment points are adjusted and sealed at the factory and should not be disturbed. Factory alignment involves multi-frequency signal generation systems, add-on test modules, output indicators and training beyond the scope of normal service activities.

The unique R-F system includes electronic tracking of R-F and oscillator circuits for maximum performance over a wide range of frequencies. THIS PERFORMANCE CAN BE DESTROYED BY AN ATTEMPT TO "PEAK UP" OR "TWEAK" OR "OPTIMIZE", ETC.

L BOARD 30-50 MHZ

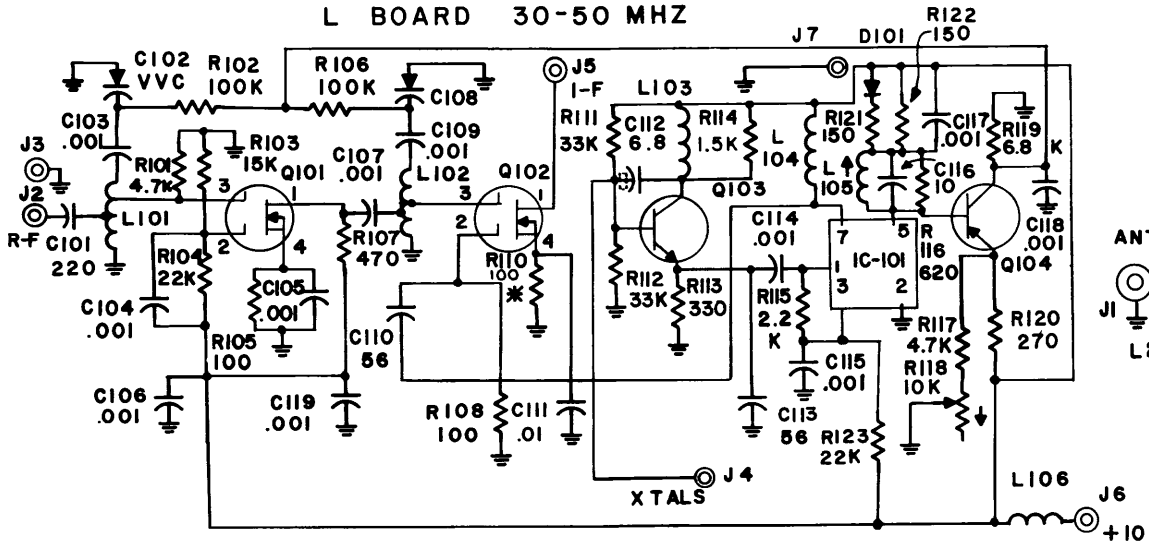

H BOARD 146-174 MHZ

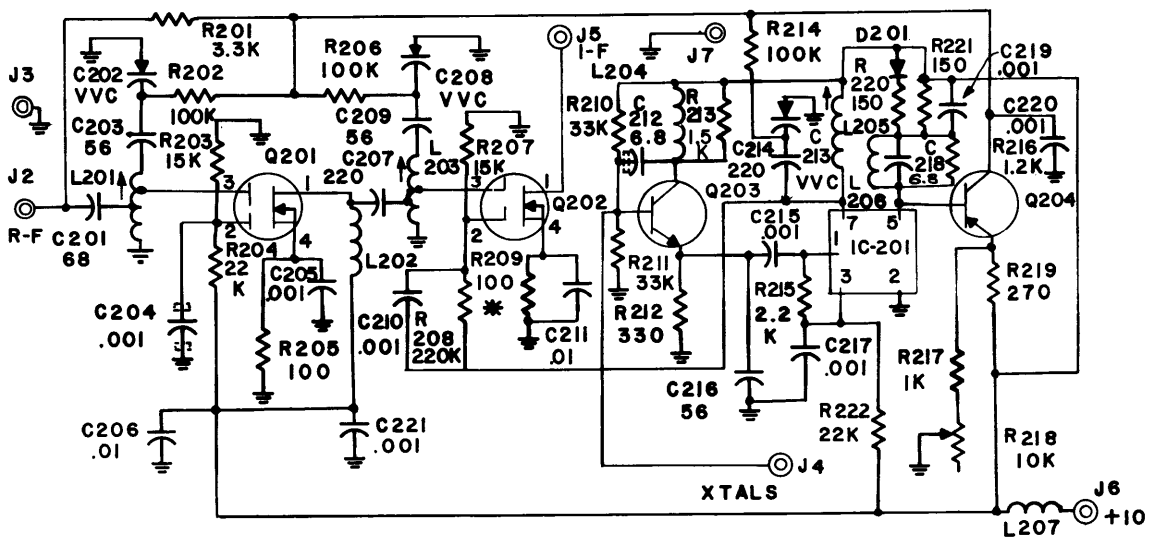

U BOARD 450-470 MHZ

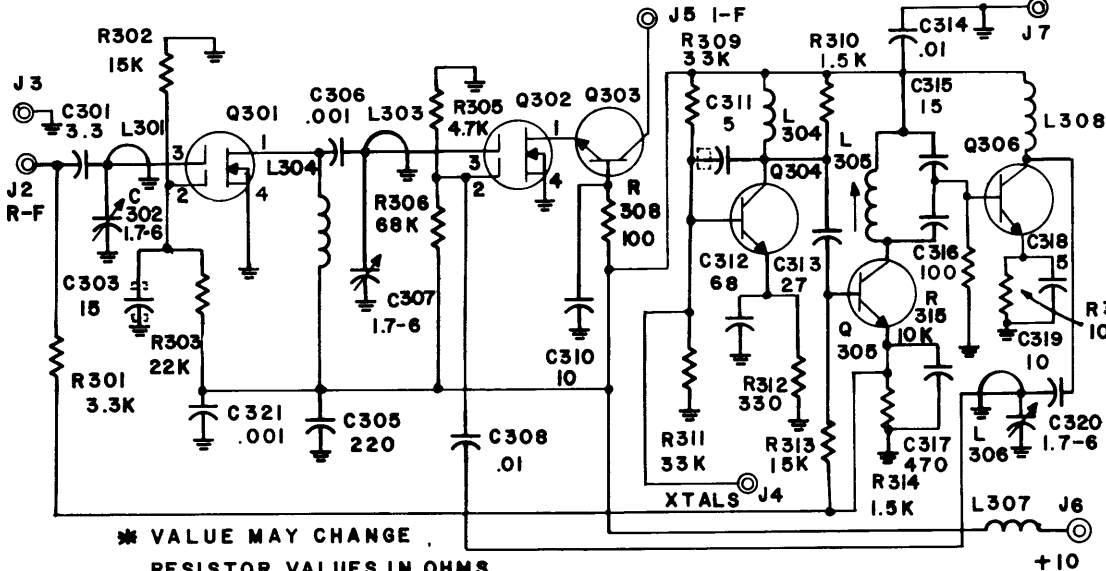

\* VALUE MAY CHANGE  
 RESISTOR VALUES IN OHMS  
 CAPACITOR VALUES BELOW 1 IN MFD  
 ABOVE 1 IN pf  
 UNLESS OTHERWISE SPECIFIED

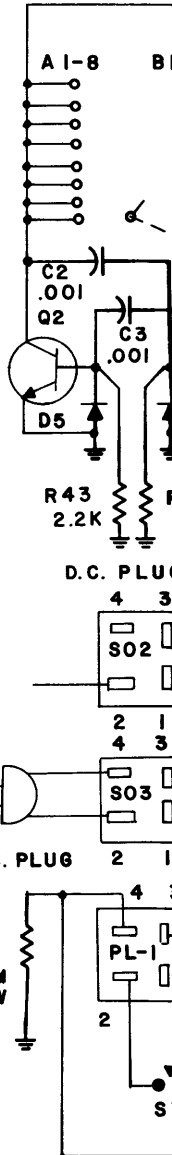
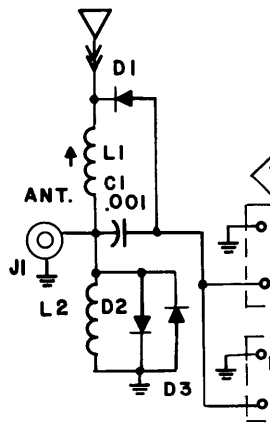

SCHEM

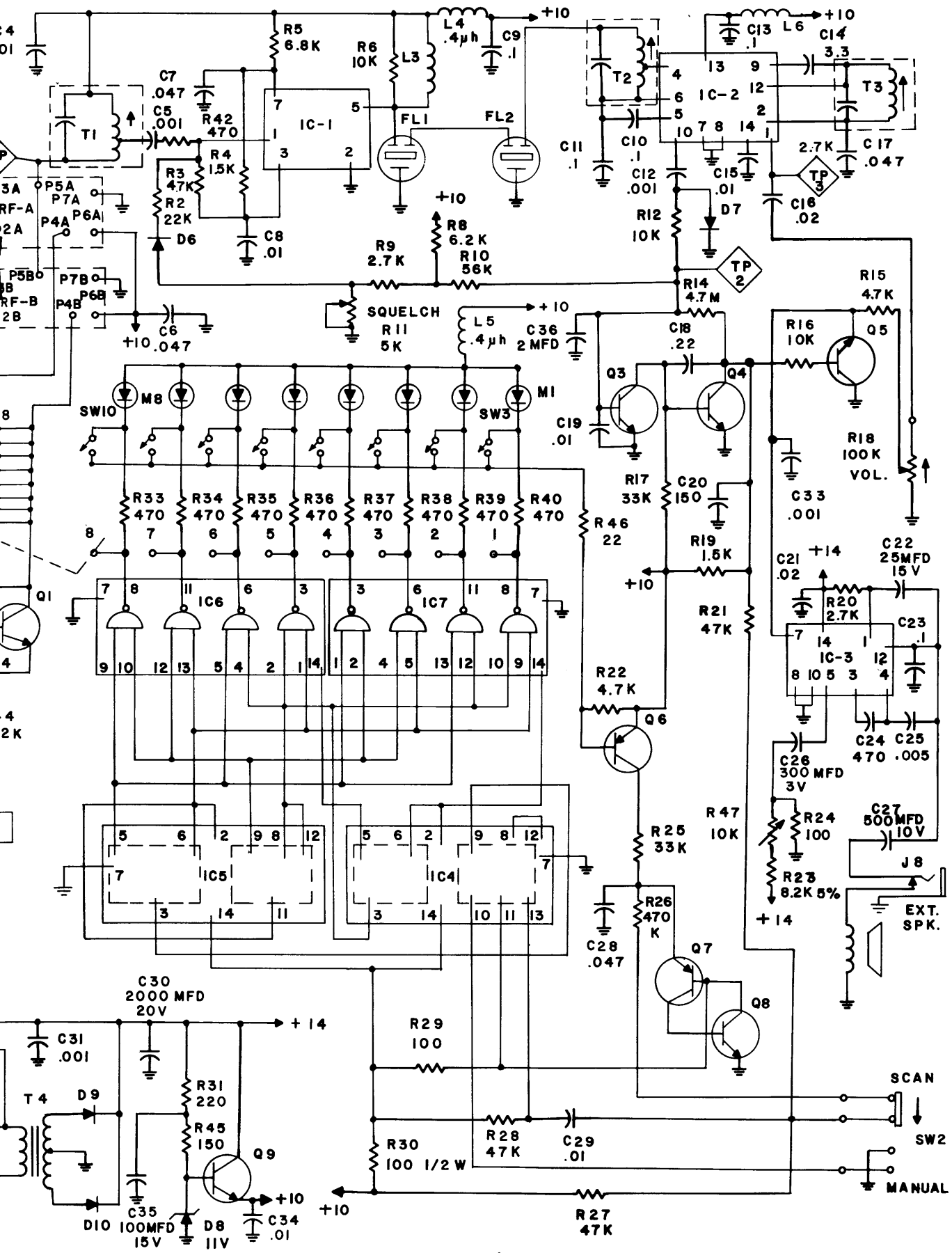

ATOMIC BC III

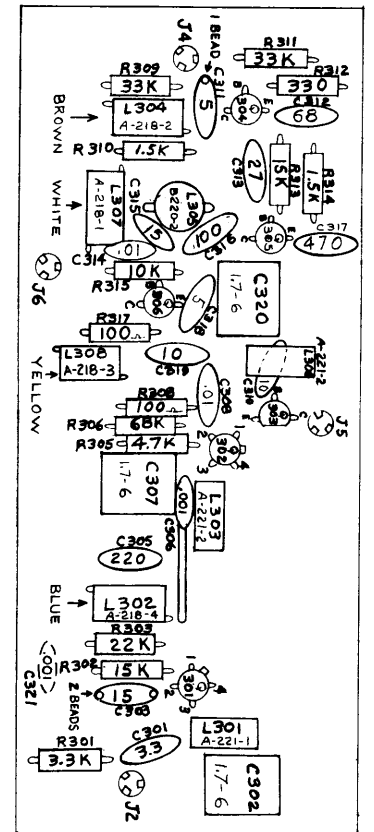
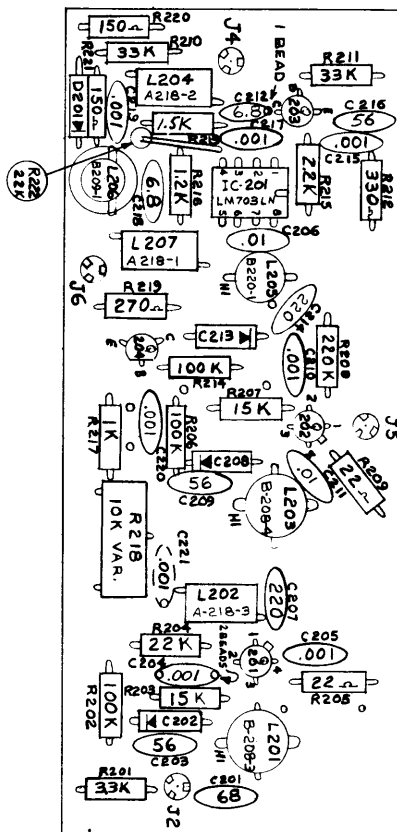
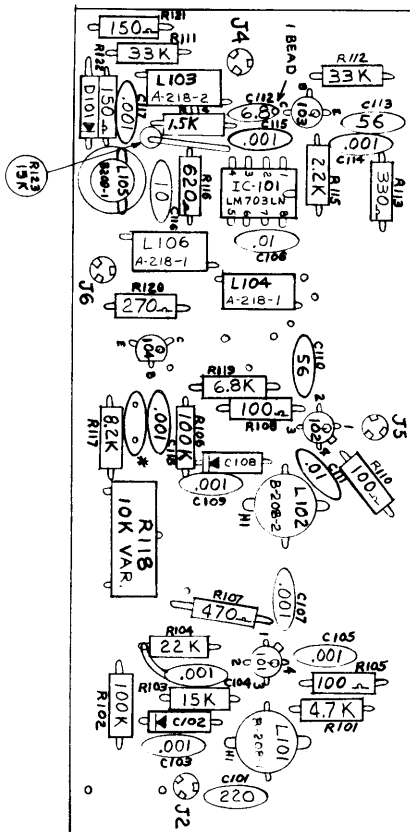
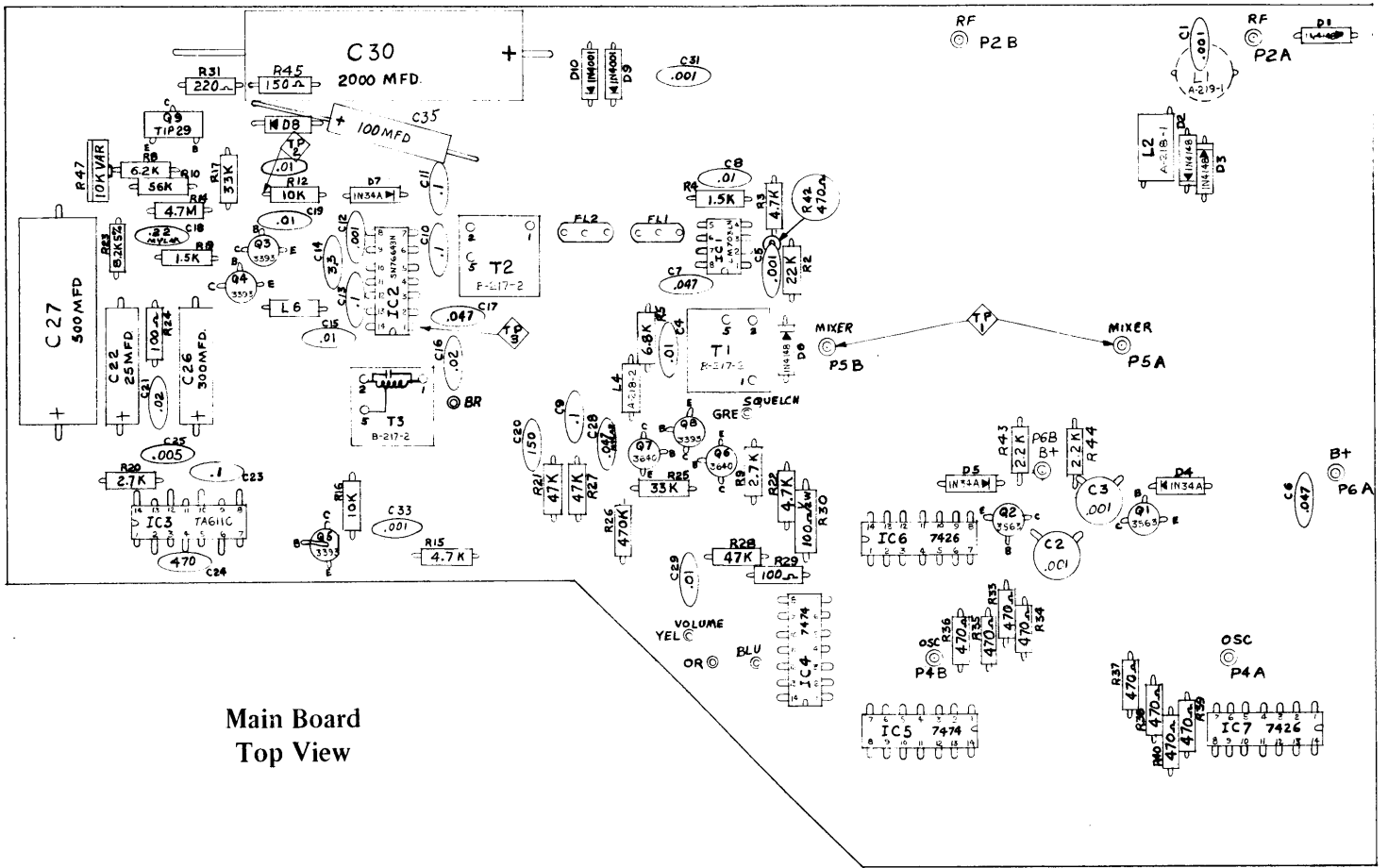



## VOLTAGE CHART

The Voltage Chart may be used as an approximate guide in following circuit operation or locating a defective stage. You should be familiar with the entire manual before attempting measurements.

TRANSISTOR VOLTAGES				
Q#	E	B	C	
# 1	GND	.2/0	0/3.2	
# 2	GND	0/.2	3.2/0	
# 3	GND	.4/.6	.7/0	
# 4	GND	.7/0	.01/9	
+ 5	0	.01/.7	GND	
+ 6	10.2	10.2	4.0/.9	
7	4.0/.9	5.8	.5	
8	GND	.5	5.8	
9	11.0	11.5	16.0	
103	3.0	3.6	10.3	
104	7.4	10.0	9.6	
203	2.9	3.6	10.2	
204	.6	9.9	9.6	
303	9.6	10.3	10.3	
304	2.9	3.4	10.3	
305	6.9	5.5	10.2	
306	.15	-.25	9.0	
...	1	2	3	4
101	8.2	3.8	0	.08
102	10.2	.16	0	.05
201	10.2	4.3	0	.2
202	10.2	.7	0	.24
301	10.3	4.2	0	.14
302	9.6	.65	0	.13

INTEGRATED CIRCUIT VOLTAGES							
PIN NO.	I.C. NUMBER						
	1	2	3	4	5	6	7
1	1.6	4.6	13	NC	NC	5.0	.1
2	GND	3.5	NC	4.4	5.0	5.0	.1
3	1.4	NC	9.1	5.0	.1	9.0	9.0
4	NC	1.4	.7	1.5	NC	5.0	.1
5	10	1.4	.5	.1	.1	.1	5.0
6	NC	1.4	NC	4.4	5.0	9.0	9.0
7	1.6	GND	0	GND	GND	GND	GND
8	NC	GND	GND	4.4	5.0	9.0	.2
9		.14	NC	.1	.1	.1	5.0
10		1.4	GND	1.4	NC	.1	5.0
11		NC	.5	6.2	5.0	9.0	9.0
12		3.5	7.9	4.4	5.0	.1	5.0
13		10	0	5.5	NC	5.0	.1
14		5.3	15	6.2	6.2	.1	4.4

Voltages are measured with "Manual-Scan" switch in manual position. "Volume" control counterclockwise and "Squelch" counterclockwise except:

- # Squelch control CW/CCW
- + Scanning/Manual
- # Crystal operating on A/B side

I.C. No.	PIN	COUNT							
		1	2	3	4	5	6	7	8
4	5	0	0	0	0	1	1	1	1
	6	1	1	1	1	0	0	0	0
	8*	1	1	1	1	1	1	1	1
	9*	0	0	0	0	0	0	0	0
5	5	0	1	0	1	0	1	0	1
	6	1	0	1	0	1	0	1	0
	8	1	1	0	0	1	1	0	0
	9	0	0	1	1	0	0	1	1
7	8	0	1	1	1	1	1	1	1
	11	1	0	1	1	1	1	1	1
	6	1	1	0	1	1	1	1	1
	3	1	1	1	0	1	1	1	1
6	3	1	1	1	1	0	1	1	1
	6	1	1	1	1	1	0	1	1
	11	1	1	1	1	1	1	0	1
	8	1	1	1	1	1	1	1	0

## LOGIC CHART

The logic sequence for counting is shown by "0" under .5v and "1" over 4v. I.C.-4, pins 8 & 9 (\*) change state on each movement, up or down, of the "Manual-Scan" Switch.

## SERVICING

It is recommended that servicing of this receiver be done by the factory service center. Special equipment and skills are maintained at the factory to give fast and efficient service on all of our products.

When returning radio receivers to the factory for service, include crystals, ac and dc power cables and telescoping antenna. Disconnect cables and antenna, pack carefully and include a brief, detailed description of the difficulty you are having.

The receiver circuitry is designed to utilize the best features of four types of semiconductors: rectifier diodes, conventional bi-polar transistors, insulated-gate field-effect transistors and integrated circuits. Servicing should not be attempted by anyone who is not familiar with the manufacturer's recommendations and cautions relating to each of these devices. The use of ohmmeters is particularly hazardous since they can deliver voltages and currents large enough to damage semiconductors.

### SERVICE PARTS LIST

(PRICES SUBJECT TO CHANGE WITHOUT NOTICE)

#### MAIN BOARD

Ref. No.	Resistors, 1/4W 10%	List Price
R-6, 12, 16.....	10k.....	\$.25
R-2.....	22k.....	.25
R-3, 22.....	4.7k.....	.25
R-4, 19.....	1.5k.....	.25
R-5.....	6.8k.....	.25
R-7.....	47.....	.25
R-8.....	5.6k.....	.25
R-9, 43, 44.....	2.2k.....	.25
R-10.....	56k.....	.25
R-13, 21, 27, 28.....	47k.....	.25
R-14.....	4.7 Meg.....	.25
R-15.....	22.....	.25
R-17, 25.....	33k.....	.25
R-20.....	2.7k.....	.25
R-24, 29, 30.....	100.....	.25
R-26.....	470k.....	.25
R-31.....	220.....	.25
R-33 thru R-40, 42.....	470.....	.25
R-41.....	1k.....	.25
R-45.....	150.....	.25
R-46.....	22.....	.25
R-47.....	10k Var.....	.75
R-23.....	*10k 1/4W, 5%.....	.25
R-32.....	2.2 MEG, 1/2W, 10%.....	.25
R-11.....	5k Squelch Cont.....	1.50
R-18.....	100k Vol. Cont. w/Switch.....	2.00
Capacitors		
C-1, 2, 3, 5, 12, 31, 33.....	.001 mf. 20% Disc. Cer.....	.50
C-4, 8, 15, 19, 29 34.....	.01mf. 20% Disc Cer.....	.50
C-6, 7, 17, 32.....	.047mf. GMV Disc. Cer.....	.50
C-9, 10, 11, 13, 23.....	.1mf. GMV Disc. Cer.....	.50
C-14.....	3.3pf 10% Disc. Cer.....	.50
C-16, 21.....	.02mf. 20% Disc. Cer.....	.50
C-18.....	.22mf. 10% Mylar.....	.50
C-20, 25.....	150pf 20% Disc. Cer.....	.50
C-22.....	25mf. 10V Lytic.....	1.00
C-24.....	100pf 20% Disc. Cer.....	.50
C-26.....	100mf. 3V Lytic.....	1.00
C-27.....	500mf. 10V Lytic.....	1.00
C-28.....	.047mf. Mylar.....	.50
C-30.....	2000mf. 20V Lytic.....	1.50
C-35.....	100mf. 15V Lytic.....	1.00
C-36.....	2mf. 35V Lytic.....	.75

Unusual circuitry in this receiver includes the automatic tuning system in the "L" and "H" modules. I.C.-101, I.C.-201 and the associated circuits generate tuning voltages to track the antenna, r-f and oscillator circuits as channels are scanned. The "U" is broadbanded in a more conventional manner. Also, when the "L" module is operating, the antenna loading coil L-1 is switched into the telescoping antenna circuit.

Audio output power is measured with bursts of modulation or by measuring the maximum excursion on voice modulation as shown on an oscilloscope. When a continuous tone is received, the output will start at full power and then decrease to approximately half power to protect the output integrated circuit from overload. It will then return to full power for voice communications.

The LED indicators have a forward voltage drop of about 1.6v at 20ma. The current should not exceed 50ma. They are polarized and may be damaged by a high reverse voltage. When a channel lamp does not light, the failure may be either the lamp or the switching I.C. If the channel works, check the lamp; if not, check the I.C. When groups of lamps are out, refer to the logic chart.

Ref. No.	Semi-Conductors	List Price
Q-1, 2.....	2N3563 F. C.....	.75
Q-3, 4, 5, 8.....	MPS3393 Mot.....	.75
Q-6, 7.....	2N3640.....	.75
Q-9.....	TIP-29 T.I.....	1.50
D-1, 2, 3, 6.....	IN4148.....	.50
D-4, 5, 7.....	IN34A.....	.50
D-8.....	IN5241B 11V 5%.....	1.00
D-9, 10.....	IN4001.....	.50
I.C.-1.....	LM703LN Nat.....	1.50
I.C.-2.....	SN76643N or ULN2111 A.....	4.00
I.C.-3.....	TA-611C S.G.S.....	5.00
I.C.-4, 5.....	SN-7474.....	2.00
I.C.-6, 7.....	SN-7426.....	1.00
M1-8.....	A-259 Light Emitting Diode.....	1.50
Inductors		
L-1.....	A-219-1 Loading Coil.....	1.00
L-2.....	A-218-1 RF Choke.....	.50
L-3.....	A-205-1 RF Choke.....	.50
L-4.....	A-218-2 RF Choke.....	.50
L-5.....	A-261.....	.50
T-1, 2, 3.....	B-217-2 I.F. Coil.....	2.00
T-4.....	B-202 Power Transformer.....	3.00
Miscellaneous		
Y61 - Y8.....	A-135 Crystal (Frequencies as required).....	5.00
Fl-1, 2.....	A-226 Crystal Filter.....	10.00
SW-2.....	B-254 "Manual-Scan" Switch.....	2.00
SW-3-10.....	Slide Switch, SPDT.....	.75
J-1.....	Antenna Connector No. 1207....	.75
	Antenna Plug No. 1200.....	.75
J-8.....	Ext. Speaker Jack No. 3512A....	1.00
PL-1.....	Power Connector P3304AB.....	1.00
SO-2, 3.....	Power Socket S-3304 FHTM.....	1.00
	DC Cord Assembly.....	1.50
	AC Cord Assembly.....	1.50
	Mobile Mounting Kit.....	2.00
SP-1.....	B-248 Speaker 3" x 5" 3.2 ohm.	3.00
	A-138-2 Telescoping Antenna....	1.50
	B-228 Front Panel.....	1.75
	C-233 Trim.....	3.00
	C-203 Wrap Assembly.....	7.50
	A-237 Antenna Bushing.....	.75
	Knob RB-155-840.....	.75

## SERVICE PARTS LIST

(Continued)

### "L" MODULE

Ref. No.	Resistors, 1/4W 10%	List Price
R-101, 117.....	4.7 k.....	\$.25
R-102, 106.....	100k.....	.25
R-103.....	15k.....	.25
R-104.....	22k.....	.25
R-105, 108, 110.....	100.....	.25
R-107.....	470.....	.25
R-111, 112.....	33k.....	.25
R-113.....	330.....	.25
R-114.....	1.5k.....	.25
R-115.....	2.2k.....	.25
R-116.....	620.....	.25
R-119.....	6.8k.....	.25
R-120.....	270.....	.25
R-121, 122.....	150.....	.25
R-123.....	22k.....	.25
R-118.....	10k variable.....	.75
Capacitors		
C-101.....	220pf 20% Disc. Cer. ....	.50
C-102, 108.....	A-225-1 VVC.....	1.50
C-103, 104, 105, 107, 109, 114, 115, 117, 118, 119.....	.001mf. 20% Disc. Cer. ....	.50
C-106, 111.....	.01mf. 20% Disc. Cer. ....	.50
C-110, 113.....	56pf 10% Disc. Cer. ....	.50
C-112.....	6.8pf 10% Disc. Cer. ....	.50
C-116.....	10pf 10% Disc. Cer. ....	.50
Semi-Conductors		
Q-101, 102.....	3N201 T.I. ....	2.50
Q-103.....	2N3563 F.C. ....	.75
Q-104.....	2N3640 .....	.75
D-101.....	1N34A.....	.50
L.C.-101.....	LM703LN Nat. ....	1.50
Inductors		
L-101.....	B-208-1 Antenna Coil .....	1.00
L-102.....	B-208-2 RF Coil.....	1.00
L-103.....	A-218-2 RF Choke.....	.50
L-104, 106.....	A-218-1 RF Choke.....	.50
L-105.....	B-209-2 Tracking Coil.....	1.00
"H" MODULE		
Resistors, 1/4W. 10%		
R-201.....	3.3k.....	.25
R-202, 206, 214.....	100k.....	.25
R-203, 207.....	15k.....	.25
R-204.....	22k.....	.25
R-205.....	22.....	.25
R-208.....	220k.....	.25
R-209.....	100.....	.25
R-210, 211.....	33k.....	.25
R-212.....	330.....	.25
R-213.....	1.5k.....	.25
R-215.....	2.2k.....	.25
R-216.....	1.2k.....	.25
R-217.....	1k.....	.25
R-219.....	270.....	.25
R-220, 221.....	150.....	.25
R-222.....	22k.....	.25
R-218.....	10k variable.....	.75
Capacitors		
C-201.....	68pf 10% Disc. Cer. ....	.50
C-202, 208, 213.....	A-258-1 VVC.....	.50
C-203, 209.....	56pf 10% Disc. Cer. ....	.50
C-207, 214.....	220pf 20% Disc. Cer. ....	.50

Ref. No.		List Price
C-204, 205, 210, 215 217, 219, 220, 221.....	.001mf. 20% Disc. Cer.....	.50
C-206, 211.....	.01mf. 20% Disc. Cer. ....	.50
C-212, 218.....	6.8pf 10% Disc. Cer. ....	.50
C-216.....	56pf 10% Disc. Cer. ....	.50
Semi-Conductors		
Q-201, 202.....	3N201 T.I. ....	2.50
Q-203.....	2N3563 F.C. ....	.75
Q-204.....	2N3640.....	.75
D-201.....	1N34A.....	.50
L.C.-201.....	LM703LN Nat. ....	1.50
Inductors		
L-201.....	B-208-3 Antenna Coil.....	1.00
L-202.....	A-218-3 RF Choke.....	.50
L-203.....	B-208-4 RF Coil.....	1.00
L-204.....	A-218-2 RF Choke.....	.50
L-205.....	B-220-1 Osc. Coil .....	1.00
L-206.....	B-209-1 Tracking Coil.....	1.00
L-207.....	A-218-1 RF Choke.....	.50

### "U" MODULE

Ref. No.	Resistors, 1/4W. 10%	List Price
R-301.....	3.3k.....	.25
R-302, 313.....	15k.....	.25
R-303.....	22k.....	.25
R-305.....	4.7k .....	.25
R-306.....	68k.....	.25
R-308, 317.....	100.....	.25
R-309, 311.....	33k.....	.25
R-312.....	330.....	.25
R-310, 314.....	1.5k.....	.25
R-315.....	10k.....	.25
R-316.....	1k.....	.25
Capacitors		
C-301.....	3.3pf 10% Disc. Cer. ....	.50
C-302, 307, 320.....	1.7-6pf variable.....	.75
C-303.....	15pf 10% Disc. Cer. ....	.50
C-305.....	220pf 20% Disc. Cer. ....	.50
C-306, 321.....	.001mf. 20% Disc. Cer. ....	.50
C-308, 314.....	.01mf. 20% Disc. Cer. ....	.50
C-310, 319.....	10pf 10% Disc. Cer. ....	.50
C-311.....	5pf 5% Disc. Cer. ....	.50
C-312.....	68pf 5% Disc. Cer. ....	.50
C-313.....	27pf 10% Disc. Cer. ....	.50
C-315.....	15pf 10% Disc. Cer. ....	.50
C-316.....	100pf 10% Disc. Cer. ....	.50
C-317.....	470pf 20% Disc. Cer. ....	.50
C-318.....	5pf 10% Disc. Cer. ....	.50
Semi-Conductors		
Q-301, 302.....	3N201 T.I. ....	2.50
Q-303, 304, 306.....	2N3563 F.C. ....	.75
Q-305.....	MPS-3393.....	.75

Ref. No.	Inductors	List Price
L-301.....	A-221-1 Antenna Coil.....	.75
L-302.....	A-218-4 RF Choke.....	.50
L-303, 306.....	A-221-2 RF Coil.....	.75
L-304.....	A-218-2 RF Choke.....	.50
L-305.....	B-220-2 RF Coil.....	.75
L-307.....	A-218-1 RF Choke.....	.50
L-308.....	A-218-3 RF Choke.....	.50

Replacement parts may be ordered directly from:

Electra Co. - P. O. Box 29243 - 300 S. County Line Rd. - Cumberland, Ind. 46229

Cash order for parts will be shipped prepaid.

RETURN WARRANTY CARD WITHIN 10 DAYS

DO NOT ABUSE OR MODIFY RADIO

NEVER REMOVE A SERIAL NUMBER

### WARRANTY

This receiver is guaranteed to be free from defects in material and workmanship. We agree to remedy such defect or to furnish a new part in exchange for any part which, under normal installation, use and service, discloses such defect, provided the receiver is delivered to us, intact, for our examination, with all transportation charges prepaid to our factory, within one year from the date of sale to the original purchaser, and provided such examination discloses, in our judgment, that it is thus defective.

This warranty does not apply if the receiver has been subjected to misuse, neglect, accidents, incorrect wiring not our own; improper installation, or to use in violation of instructions furnished by us, nor to receivers that have been repaired or altered outside our factory.

This warranty excludes all oral or other implied warranties, and the manufacturer shall in no event be liable for damages for a breach of warranty in an amount exceeding the purchase price of the alleged defective equipment.

TO PLACE WARRANTY IN FORCE FILL OUT AND RETURN WARRANTY CARD WITHIN TEN (10) DAYS OF PURCHASE.

**ELECTRA COMPANY**  
DIVISION OF MASCO CORPORATION  
300 East County Line Rd., South  
Cumberland, Indiana 46229

IM-201-2