



**ORDER NO. 380S**

**Model 2BDQ-S**

**Trap Dipole Antenna**

# INSTRUCTION MANUAL

## **General Description**

The Hy-Gain Model 2BDQ-S is a 1/2 wavelength, dipole antenna for 40 and 80 meters. Band switching is accomplished automatically through the use of two matched Hy-Gain 40-meter Hy-Q traps. The maximum overall length is 100' 10 1/2". If the antenna is mounted in an inverted "V" configuration, the overall length will be shortened.

The balun will improve the performance and efficiency of the 2BDQ-S. The Hy-Gain Model BN-86 is a broadband balun designed specifically for dipole-type antennas. The balun balances the input impedance to the antenna and prevents transmission line radiation.

## **Theory of Operation**

Matched H<sup>y</sup>-Gain Hy-Q traps give true 1/2-wave resonance. They are tuned at the factory and no adjustments are necessary. They operate as a high impedance circuit on 40 meters and add to the overall length of the antenna as center loading for the 80/75 meter resonance.

## **Construction**

The Hy-Q traps will withstand hard wear and severe weather conditions. All hardware is passivated stainless steel. The center of the dipole is supported with a yoke-type center insulator to which the transmission line attaches. The ends of the dipole are supported by two end insulators constructed of high impact ABS plastic. The antenna wire is Alumoweld® #12, which resists rust and has a breaking strength of 1200 pounds.

## **SWR and Feedline**

The 2BDQ-S antenna is designed for use with single 50 ohm coaxial feedline. The SWR at resonance is 1.5:1 or less on both bands. RG58/U or RG213/U is recommended.

## Specifications

### *Mechanical*

Overall Length..... 100' 10 1/2" maximum (30.74 m)  
 Maximum Wind Survival ..... 80 mph (129 kmph)  
 Antenna Wire ..... Alumoweld® #12

### *Electrical*

Frequency Range ..... 40 and 80 meters  
 Input Impedance ..... 50 ohms unbalanced  
 SWR at Resonance ..... less than 1.5:1  
 Maximum Power ..... 1 kW

### Assembly Procedure

Referring to Figure 1, place one half of the center insulator (Item No.7) on a flat surface with the inside facing up.

Assemble the hardware on the eyebolts and place in the insulator.

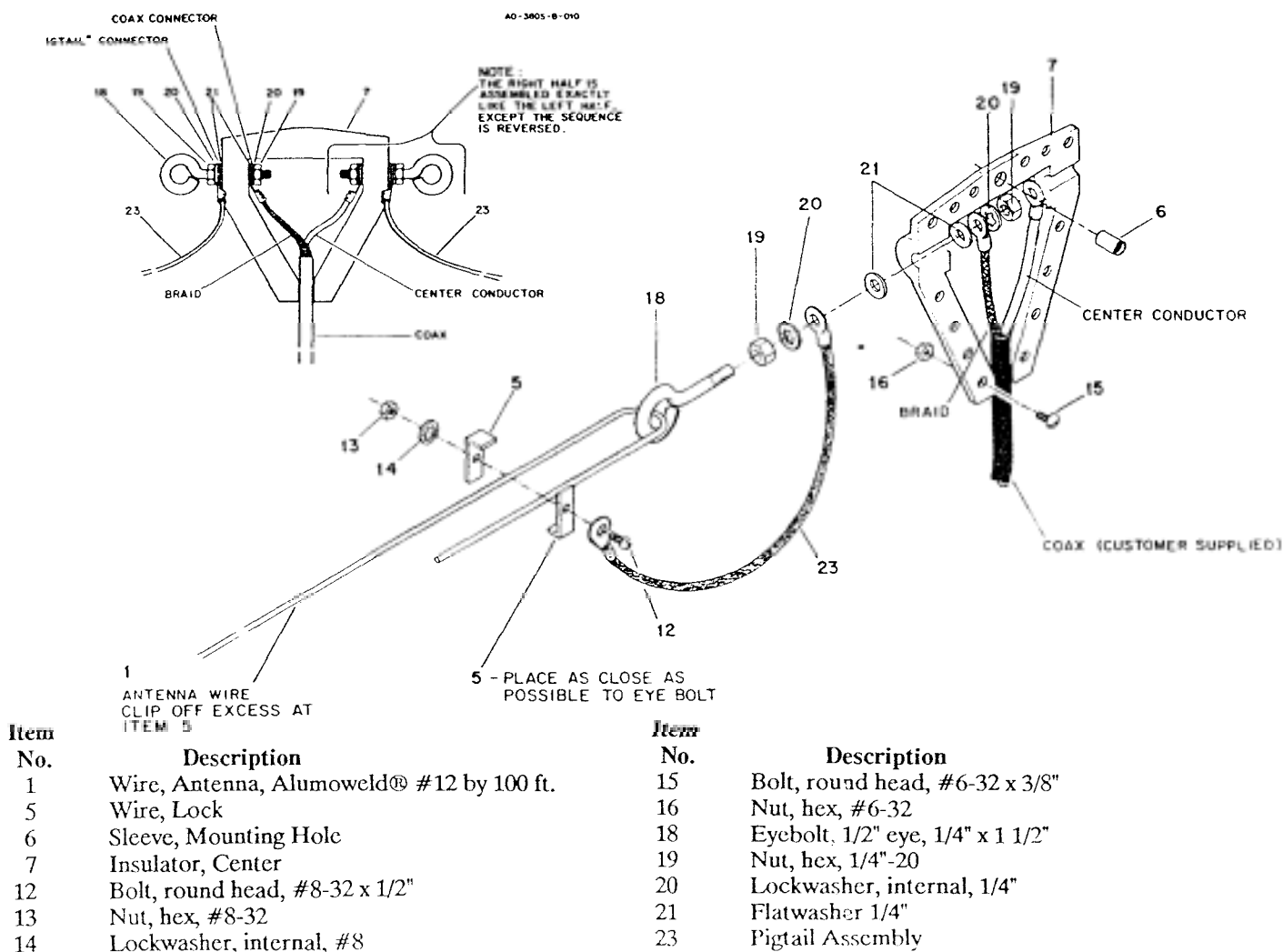

Figure 1 Assembly of Antenna Wire to Center Insulator

Strip the coax and separate the center conductor from the braid. Solder the braid to one solder lug (Item No. 22) and the center conductor to the other solder lug. For a smaller coax, a reducing sleeve is provided.

Apply silicone grease or Vaseline®, etc. (not supplied) to the mating halves.

Place the halves together and secure them using the #6-32 x 3/8" bolts and nuts (Item Nos. 15 & 16).

Hold the eyebolt to keep it from turning and tighten the 1/4" nuts on the outside, first one side and the other.

NOTE: Both sides of the antenna are exactly the same. Each of the following steps must be done first for one side then repeated for the other side.

Cut the 40-meter wire (LI) to either Phone or Continuous Wave (CW) dimensions as shown in Figures 2 and 3. Add an extra three inches on each end for attaching to the center insulator and 40-meter trap. *Example:* LI length for CW operation is 19' 8 1/4". Add six inches, three inches each end, which makes a total length of 20' 2 1/4". Each insulator or trap requires three inches for proper attachment.

NOTE: When you have selected your mode of transmission (Phone or CW), you must use the same mode for all dimensions.

Attach one end of the wire (just cut) to the center insulator (Item No.7) using the wire locks as shown in Figure 1. Do not forget to connect the pigtail to the wire lock.

Clip off all excess wire extending past the wire lock.

Select the 40-meter trap and the trap connector clamps. Assemble the clamps on both ends of the trap using the #10-24 x 1 1/2" bolts, lockwashers, and nuts (Item Nos. 9, 11, and 10), as shown in Figure 4.

Carefully remeasure the antenna wire connected to the center insulator and bend the wire for attachment to the 40-meter trap as shown in Figures 2 and 3.

Connect the wire to the trap using the wire locks (Item No. 5) and shown in Figure 4. Clip off all excess wire extending past the wire lock.

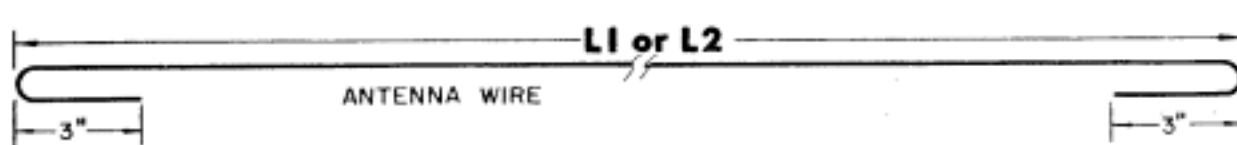
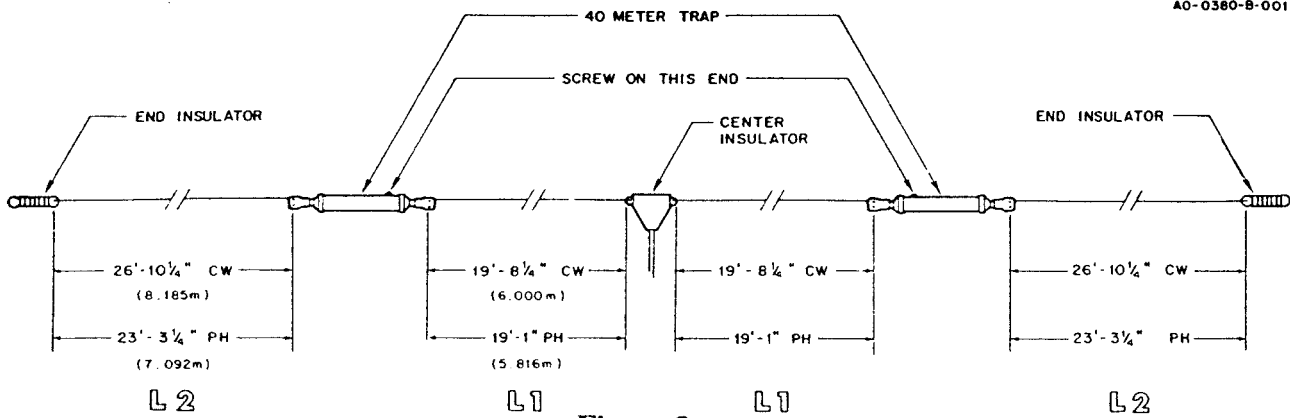

Figure 2 Antenna Wire Measurements



**Figure 3**  
**Overall View**

NOTE: The end of the trap which has a small bolt must be pointed in the direction of the center insulator as shown in Figures 3 and 4. This is very important for proper operation of the antenna.

Use only one bolt on the side of the clamp opposite the drain holes. An off-center wire attachment is used to keep the drain holes downward. Remove the twists and kinks from the wire prior to the installation to insure that the traps do not rotate in the final mounting position.

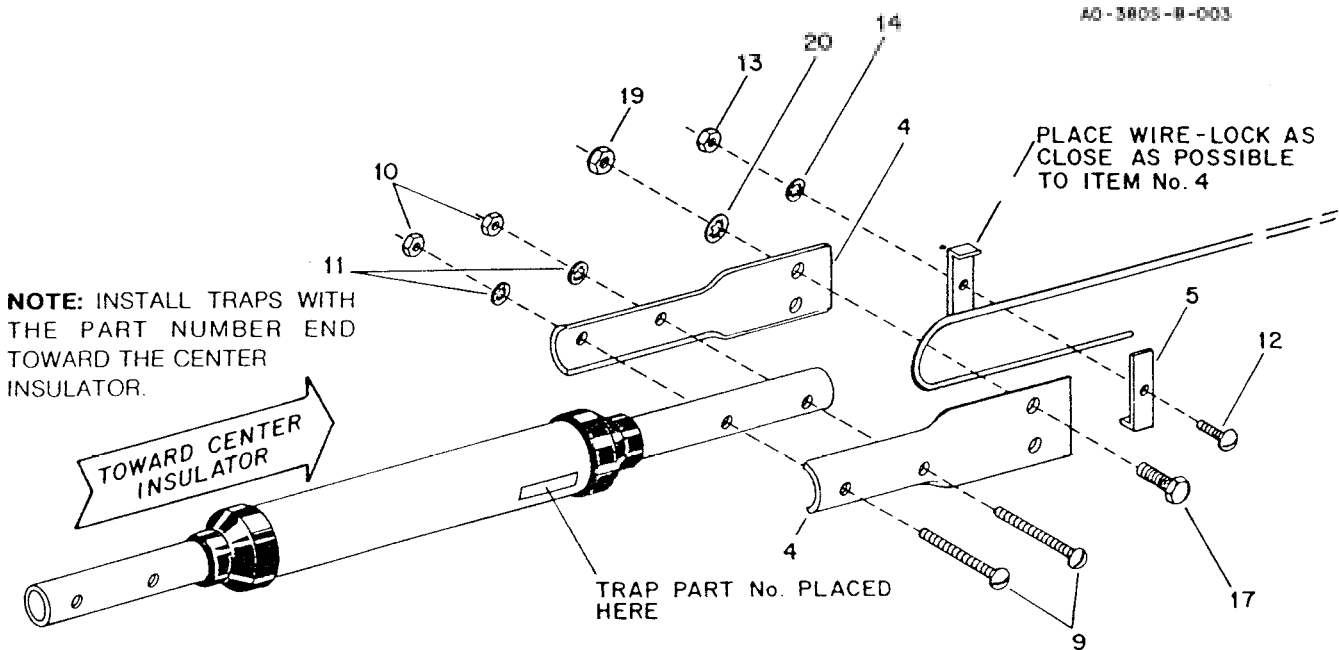

| Item No. | Description                      | Item No. | Description               |
|----------|----------------------------------|----------|---------------------------|
| 4        | Clamp, Trap Connector            | 13       | Nut, hex, #8-32           |
| 5        | Wire Lock                        | 14       | Lockwasher, internal, #8  |
| 9        | Bolt, hex head, #10-24 x 1 1/2"  | 17       | Bolt, hex head, 1/4"-20 x |
| 10       | Nut, hex, #10-24                 | 19       | Nut, hex, 1/4"-20         |
| 11       | Lockwasher, internal, #10        | 20       | Lockwasher, internal 1/4" |
| 12       | Bolt, round head, #8-32 x 1 1/2" |          |                           |

**Figure 4 Assembly of the Antenna Wire to the Traps**

Cut the 80-meter antenna wire (L2) to the length shown for your mode of transmission (Phone or CW). Do not forget to allow an extra three inches on each end for attachment to the 40-meter trap and end insulator.

Bend one end of the wire and attach to the 40meter trap as shown in Figures 2 and 4. Do not forget to clip off the excess wire extending past the wire lock.

Carefully remeasure wire and bend for attachment to the end insulator.

Attach the wire to the end insulator as shown in Figure 5. Clip off all excess wire extending past the wire lock.

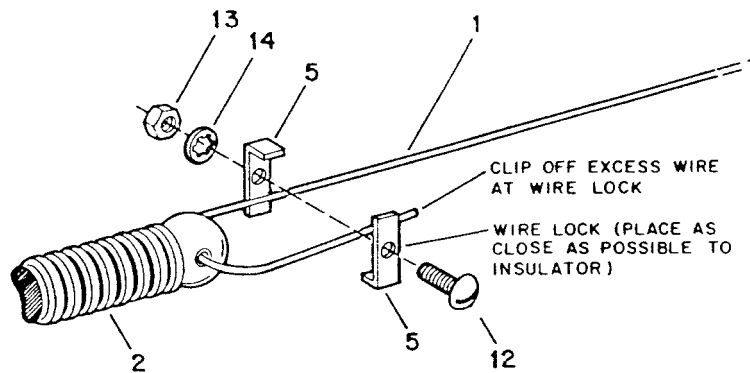

Item

No. Description

- |    |   |
|----|---|
| 1  | Wire, Antenna, Alumoweld #12 by 100 ft. |
| 2  | Insulator, End                          |
| 5  | Wire Lock                               |
| 12 | Bolt, round head, #8-32 x 1/2"          |

Figure 5

Assembly of the Antenna Wire to the End Insulator

### Mounting

The antenna is now ready to be mounted in either the horizontal or inverted "V" configuration. Refer to Figures 6 and 7 for proper dimensions. When suspending the end insulators, non-metallic line is preferred. If you do use wire, it must be broken up every six feet with strain insulators to prevent harmful effects to your radiation pattern.

Suspend the antenna by attaching the end insulators to a *stable* structure. The center insulator may be supported by the antenna itself or suspended from a support. When suspending the center insulator from a support, be sure to keep the insulator from contacting any of the supporting structure. For proper operation of this antenna, the center insulator should be about 46 feet above the ground. The higher the antenna, the better the operation.

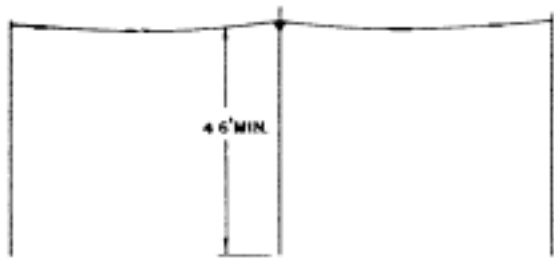

A 46' minimum is the recommended height of the center insulator. It can be less if necessary.

Figure 6 Horizontal Mounting

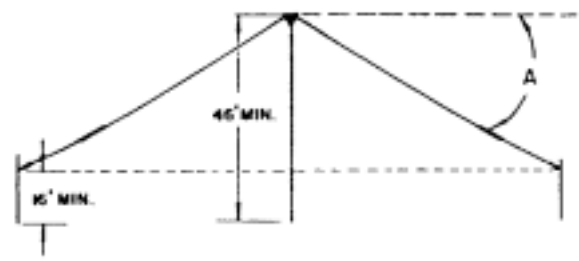

If angle "A" becomes greater than 35 degrees, the antenna will be directional.

Figure 7 Inverted "V" Mounting

It is extremely important that the antenna be mounted in the clear. Detrimental effects of surrounding objects is often underestimated in the average antenna installation. In particular, power lines and other metal objects of considerable length or mass will deteriorate the performance of any antenna. When installing the antenna, keep the two halves balanced with respect to ground and surrounding objects. Do not attempt to remove all the sag or tremendous strain will develop which could cause mechanical failure. A few feet of sag in the antenna wire will not harm the performance of the 2BDQ-S either mechanically or electrically.

A Model 2BDQ-S may be mounted in the inverted "V" configuration as shown by the drawings in this manual. Care must be taken to insure that the ends of the antenna are at least 16 feet above the ground. Keep the antenna balanced. Anything you do to one end must also be done to the other end or serious deterioration in performance will result. One advantage of the inverted "V" is that you can more nearly match the antenna impedance to the transmission line impedance. A directional pattern, in the direction of the slant, will result if angle "A" (as shown in Figure 7) exceeds 35 degrees.

### VSWR Charts

Figure 8 shows typical SWR curves for this antenna mounted approximately 50 feet above ground.

The optimum heights for this antenna on 40 meters would be between 20 and 30 feet or greater than 70 feet. The optimum heights for this antenna on 80 meters would be between 30 and 70 feet. Heights other than these will produce SWR in excess of 1.5:1.

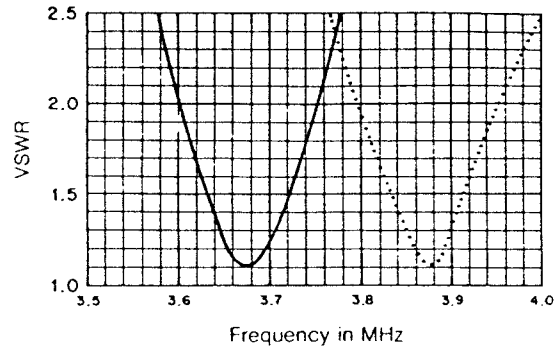
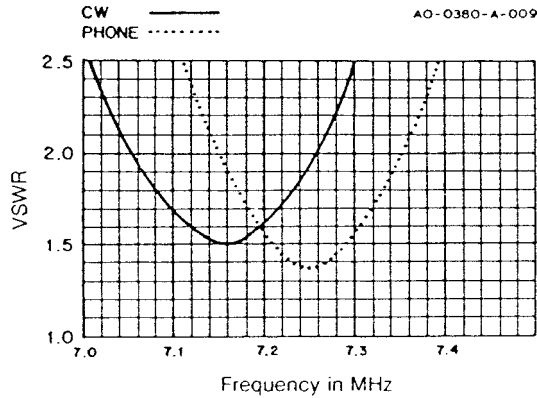

**Figure S Typical SWR Curves for  
this Antenna Installed 50 feet  
Above Ground**

**Hints on Handling Alumoweld© Wire**

To meet the numerous requests for a non-corrosive, super strength wire, Hy-Gain is now using Alumoweld© wire in many wire-type antennas and mounting kits.

Alumoweld© wire meets Military Specifications for virtually all environmental conditions. The wire is designed for arcs of high humidity and salt exposures as well as other less durable forms of wire but the lasting properties are far superior. Conducting properties closely approach that of pure aluminum making it ideal electrically for RF use.

There may be some difficulty encountered in working with the wire due to its tendency to kink. Kinks may be removed by a pole or similar stationary curved object and working the wire back and forth as shown in Figure 9.

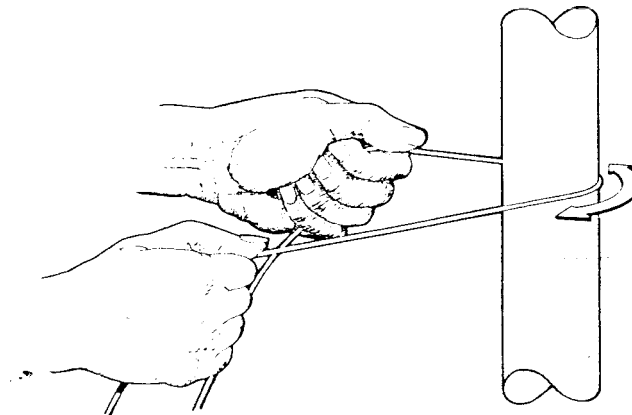

**Figure 9 Removing Kinks from  
Alumoweld Wire**

## PARTS LIST

| Item No. | Part No. | Description Qty                              |
|----------|----------|--|
| 1        | 691067   | Wire, Antenna, Alumowel #12 by 100 ft. ....1 |
| 2        | 861021   | Insulator, End.....2                         |
| 3        | 877234   | Trap Assembly, 40-Meter.....2                |
|          | 877233-1 | Parts Pack 380S, Stainless Steel ..... 1     |
| 4        | 167236   | Clamp, Trap Connector..... 8                 |
| 5        | 167238   | Wire Lock.....16                             |
| 6        | 171586   | Sleeve, Mounting Hole..... 1                 |
| 7        | 465460   | Insulator, Center.....2                      |
| 8        | 465570   | Plug, Center Insulator Adaptor..... 1        |
| 9        | 500159   | Bolt, hex head, #10-24 x 11/2 ".....8        |
| 10       | 554071   | Nut, hex, # 10-24..... 8                     |
| 11       | 565697   | Lock washer, internal, #10 ..... 8           |
| 12       | 500185   | Bolt, round head, #8-32 x 1/2" ..... 8       |
| 13       | 550063   | Nut, hex, #8-32.....8                        |
| 14       | 560035   | Lockwasher, internal, #8....., 8             |
| 15       | 501118   | Bolt, round head, #6-32 x 3/8".....,14       |
| 16       | 555888   | Nut, hex, #6-32.....14                       |
| 17       | 505266   | Bolt, hex head, 1/4"-20 x 3/4"....., 4       |
| 18       | 540066   | Eyebolt, 1/2" eye, 1/4" x 11/2 " .....2      |
| 19       | 554099   | Nut, hex, 1/4"-20.....14                     |
| 20       | 562961   | Lockwasher, internal, 1/4" ..... 8           |
| 21       | 566344   | Flatwasher, 1/4".....4                       |
| 22       | 677555   | Lug, Solder..... 2                           |
| 23       | 878466   | Pigtail Assembly ..... 2                     |

### Converting American to Metric

Use this scale to identify lengths of bolts, diameters of tubes, etc.. The American inch (1") and foot (1') can be converted to centimeters in this way.

$$1 \text{ inch (1")} = 2.54 \text{ cm}$$

$$1 \text{ foot (1')} = 30.48 \text{ cm}$$

Example

$$42" \times 2.54 = 106.7 \text{ cm}$$

